

# Section 17

## Industrial Engineering

BY

**B. W. NIEBEL** *Professor Emeritus of Industrial Engineering, The Pennsylvania State University.*  
**SCOTT JONES** *Professor, Department of Accounting, College of Business and Economics, University of Delaware.*  
**ASHLEY C. COCKERILL** *Senior Engineer, Motorola Corp.*  
**VINCENT M. ALTAMURO** *President, VMA, Inc., Toms River, NJ.*  
**ROBERT J. VONDRASEK** *Assistant Vice President of Engineering, National Fire Protection Assoc.*  
**JAMES M. CONNOLLY** *Section Head, Projects Department, Jacksonville Electric Authority.*  
**EZRA S. KRENDEL** *Emeritus Professor of Operations Research and Statistics, Wharton School, University of Pennsylvania.*

### 17.1 INDUSTRIAL ECONOMICS AND MANAGEMENT by B. W. Niebel

Plant Organization	17-2
Process Planning	17-3
Process Analysis	17-3
Just-in-Time Techniques, Manufacturing Resource Planning, and	
Production Control	17-4
Total Quality Control	17-6
Control of Materials	17-6
Strategic Economic Evaluations	17-7
Optimization Techniques	17-7
Wage Administration	17-10
Employee Relations	17-10

### 17.2 COST ACCOUNTING by Scott Jones

Role and Purpose of Cost Accounting	17-11
Measuring and Reporting Costs to Stockholders	17-12
Classifications of Costs	17-12
Methods of Accumulating Costs in Records of Account	17-14
Elements of Costs	17-14
Activity-Based Costing	17-15
Management and the Control Function	17-15
Types of Cost Systems	17-16
Budgets and Standard Costs	17-16
Transfer Pricing	17-17
Supporting Decision Making	17-17
Capital-Expenditure Decisions	17-18
Cost Management	17-18

### 17.3 ENGINEERING STATISTICS AND QUALITY CONTROL by Ashley C. Cockerill

Engineering Statistics and Quality Control	17-19
Statistics and Variability	17-19
Characterizing Observational Data: The Average and Standard Deviation	17-19
Process Variability—How Much Data?	17-20
Correlation and Association	17-21
Comparison of Methods or Processes	17-21
Go/No-Go Data	17-23
Control Charts	17-24

### 17.4 METHODS ENGINEERING by Vincent M. Altamuro

Scope of Methods Engineering	17-25
Process Analysis	17-25
Workplace Design	17-26
Methods Design	17-26
Elements of Motion and Time Study	17-26
Method Development	17-26
Operation Analysis	17-26
Principles of Motion Study	17-27
Standardizing the Job	17-28
Work Measurement	17-28
Time Study Observations	17-28
Performance Rating	17-29
Allowances for Fatigue and Personal and Unavoidable Delays	17-31
Developing the Time Standard	17-31
Time Formulas and Standard Data	17-31
Uses of Time Standards	17-32

### 17.5 COST OF ELECTRIC POWER by Robert J. Vondrasek and James M. Connolly

Constructed Plant Costs	17-32
Fixed Charges	17-35
Operating Expenses	17-36
Overall Generation Costs	17-37
Transmission Costs	17-38
Power Prices	17-38

### 17.6 HUMAN FACTORS AND ERGONOMICS by Ezra S. Krendel

Scope	17-39
Psychomotor Behavior	17-39
Skills and Errors	17-40
Manual Control	17-40
McRuer's Rule	17-41
Crossover Frequency	17-41

### 17.7 AUTOMATIC MANUFACTURING by Vincent M. Altamuro

Design for Assembly	17-42
Autofacturing Subsystems	17-43

## 17.1 INDUSTRIAL ECONOMICS AND MANAGEMENT

by B. W. Niebel

REFERENCES: Fabrycky and Thuesen, "Economic Decision Analysis," Prentice-Hall. Niebel, "Motion and Time Study," Irwin. Moore, "Manufacturing Management," Irwin. Folts, "Introduction to Industrial Management," McGraw-Hill. Bock and Holstein, "Production Planning and Control," Merrill. Mayer, "Production Management," McGraw-Hill. Maynard, "Handbook of Modern Manufacturing Management," McGraw-Hill. Eary and Johnson, "Process Engineering for Manufacturing," Prentice-Hall. Shamblin and Stevens, "Operations Research—A Fundamental Approach," McGraw-Hill. Fay and Beatty, "The Compensation Sourcebook," Human Resource Development Press.

### PLANT ORGANIZATION

**Organization** generally is recognized as the foundation of management. The term, as it is used in industry and business, means the distribution of the functions of the business to the personnel logically qualified to handle them. It should be noted that the organization should be built around functions rather than individuals.

In the past and to a large extent today, the majority of progressive concerns are organized on a **line-and-staff** basis. The relationships usually are shown on an **organization chart**, which reveals the relationships of the major divisions and departments and the lines of direct authority from superior to subordinate. Lines of authority usually are shown as vertical lines. **Staff authority** frequently is indicated by a dotted line, which distinguishes it from direct authority. This same procedure is usually used to indicate committee relationships. Departments or activities are clearly identified within framed rectangles. The names of individuals responsible for a given department or activity often are included with their job organization titles. Although the organization chart shows the relationship of organization units, it does not clearly define the responsibilities of the individuals and the groups. Thus organization charts must be supplemented with carefully prepared job descriptions for all members of the organization. **Position descriptions** are written definitions of jobs enumerating the duties and responsibilities of each position.

A **line organization** comprises those individuals, groups, and supervising employees concerned directly with the productive operation of the business. The paths of authority are clearly defined, as each individual has but one superior from whom he or she obtains orders and instructions. This superior reports to but one individual, who has complete jurisdiction over his or her operation and supplies necessary technical information. In large- and middle-sized organizations, a pure line-type enterprise cannot exist because of the complexity of our business society.

A **staff organization** involves personnel, departments, or activities that assist the line supervisor in any advisory, service, coordinating, or control capacity. It should be noted that a staff position is a full-time job and is essentially the work of a specialist. Typical staff functions are performed by the company's legal department, controller, and production control. Figure 17.1.1 illustrates a typical line-staff activity.

Committees are used in some instances. A committee is a group of individuals which meets to discuss problems or projects within its area of assigned responsibility in order to arrive at recommendations or decisions. A **committee** operates on a staff basis. Although committees are time-consuming and frequently delay action, their use combines the experience and judgment of several persons, rather than a single individual, in reaching decisions.

The control of organization is the responsibility of two groups of management: (1) **administrative management**, which has the responsibility for determining policy and coordinating sales, finance, production, and distribution, and (2) **production management**, which has the responsibility for executing the policies established by administration.

In building an efficient organization, management should abide by certain principles, namely:

1. Clear separation of the various functions of the business should be established to avoid overlap or conflict in the accomplishment of tasks or in the issuance or reception of orders.
2. Each managerial position should have a definite location within the organization, with a written job specification.
3. There should be a clear distinction between line and staff operation and control.
4. A clear understanding of the authority under each position should prevail.
5. Selection of all personnel should be based on unbiased techniques.
6. A recognized line of authority should prevail from the top of the organization to the bottom, with an equally clear line of responsibility from the bottom to the top.
7. A system of communication should be well established and definitely known—it should be short, yet able to reach rapidly everyone in the organization.

Staff members usually have no authority over any portion of the organization that the staff unit assists. However, the department or division that is being assisted by the staff can make demands upon the staff to provide certain services. There are instances where a control type of staff may be delegated to direct the actions of certain individuals in the organization that they are servicing. When this takes place, the delegated authority may be termed **staff authority**; it is also frequently known as **functional authority** because its scope is determined by the functional specialty of the staff involved.

Many businesses today are finding it fruitful to establish "temporary organizations" in which a team of qualified individuals, reporting to management, is assembled to accomplish a mission, goal, or project, and then this organization is disbanded when the goal is reached.

The term **virtual corporation** is used to identify those combinations of business and industry where technology is used to execute a wide array of temporary alliances in order to grasp specific market opportunities. With business becoming more complex and global, it is highly likely there will be more partnerships emerging among companies and entrepreneurs. Thus today's joint ventures, strategic alliances, and outsource-

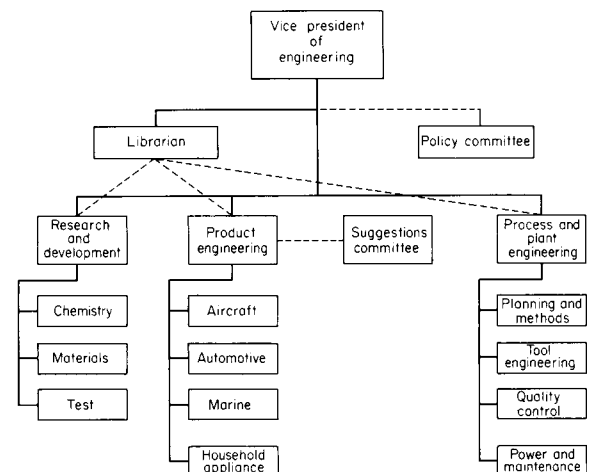

Fig. 17.1.1 Organization chart illustrating the activities reporting to the vice president of engineering.

ing will expand to the virtual corporation utilizing high-speed communication networks. Here, common standards will be used allowing for interchange of design drawings, specifications, and production data.

Thus many businesses and industries are deviating from the classic line-and-staff organization into a more horizontal organizational structure. Each partner in the organization brings its core competence to the effort. Thus, it becomes practical for companies to share skills, costs, and global markets, making it easier to manage a large enterprise since others will be managing components of it for them.

In such organizations there is a strong trend toward **project teams** made up of qualified persons, reporting to management, who are given the authority to do a project (short or long term), complete it, and then be restructured. These project teams frequently are referred to as "temporary organizations." This type of organization characterizes **participative management**. Here position descriptions become less important than functional assignments. An extension of participative management is employee-owned companies in which employees not only assume a production role but also the decision-making shareholder type of role.

**Good organization requires** that (1) responsibilities be clearly defined; (2) responsibility be coupled with corresponding authority; (3) a change in responsibility be made only after a definite understanding exists to that effect by all persons concerned; (4) no employee be subject to definite orders from more than one source; (5) orders not be given to subordinates over the head of another executive; (6) all criticism be made in a constructive manner and be made privately; (7) promotions, wage changes, and disciplinary action always be approved by the executive immediately superior to the one directly responsible; (8) employees whose work is subject to regular inspection or appraisal be given the facilities to maintain an independent check of the quality of their work.

## PROCESS PLANNING

Process planning encompasses selecting the best process to be used in the most advantageous sequence, selecting the specific jigs, fixtures, gages, etc. to be used, and specifying the locating points of the special tools and the speeds, feeds, and depths of cut to be employed.

The processes that take place in transforming a part from chosen raw material to a finished piece include the following.

**Basic Processes** The first processes used in the sequence that leads to the finished design.

**Secondary Processes** Those operations required to transform the general form created by the basic process to product specifications. These include:

1. **Critical manufacturing operations** applied to areas of the part where dimensional or surface specifications are sufficiently exacting to require quality control or used for locating the workpiece in relation to other areas or mating parts.
2. **Placement operations** whose method and sequence are determined principally by the nature and occurrence of the critical operations. Placement operations prepare for a critical operation or correct the workpiece to return it to its required geometry or characteristic.
3. **Tie-in operations**, those productive operations whose sequence and method are determined by the geometry to be imposed on the work as it comes out of a basic process or critical operation in order to satisfy the specification of the finished part. Thus, tie-in operations are those secondary productive operations which are necessary to produce the part, but which are not critical.
4. **Protection operations**, those necessary operations that are performed to protect the product from the environment and handling during its progress through the plant and to the customer, and also those operations that control the product's level of quality.

Effective process planning requires the consideration of a large number of manufacturing aspects. Today, the modern computer is able to make the many comparisons and selections in order to arrive at an economic plan that will meet quality and quantity requirements. With computerized planning, considerably less time is required and it can be completed by a technician having less factory experience than needed for manual planning.

## PROCESS ANALYSIS

**Process analysis** is a procedure for studying all productive and nonproductive operations for the purpose of optimizing cost, quality, throughput time, and production output. These four criteria are not mutually exclusive and they are not necessarily negatively correlated. High quality with few if any rejects can result in high production output with low throughput time and cost. All four of these criteria need to be addressed if a facility is going to be a world competitor producing a quality product. It is possible, for example, to have high productivity with efficient equipment producing good quality, but still fall short in the competitive world because of excessive throughput time. The high throughput time will cause poor deliveries and high cost due to excessive in-process inventory resulting from poor planning and scheduling.

In applying process analysis to an existing plant producing a product line, the procedure is first to acquire all information related to the volume of the work that will be directed to the process under study, namely, the expected volume of business, the chance of repeat business, the life of the job, the chance for design changes, and the labor content of the job. This will determine the time and effort to be devoted toward improving the existing process or planning a new process.

Once an estimate is made of quantity, process life, and labor content, then all pertinent factual information should be collected on operations; facilities used for transportation and transportation distances; inspections, inspection facilities, and inspection times; storage, storage facilities, and time spent in storage; vendor operations, together with vendor prices; and all drawings and design specifications. When the information affecting cost and method is gathered, it should be presented in a form suitable for study, e.g., a **flow process chart**. This chart presents graphically and chronologically all manufacturing information. Studies should be made of each event with thought toward improvement. The recommended procedure is to take each step in the present method individually and analyze it with a specific approach toward improvement, considering the key points of analysis. After each element has been analyzed, the process should be reconsidered with thought toward overall improvement. The primary approaches that should be used when analyzing the flow chart include (1) purpose of operation, (2) design of parts, (3) tolerances and specifications, (4) materials, (5) process of manufacture, (6) setup and tools, (7) working conditions, (8) materials handling, (9) plant layout, and (10) principles of motion economy. (See also Sec. 12.1, "Industrial Plants.")

**Purpose of Operation** Many operations can be eliminated if sufficient study is given the procedural process. Before accepting any operation as necessary, its purpose should be clearly determined and **checklist questions** should be asked to stimulate ideas that may result in eliminating the operation or some component of it. Typical checklist questions are: Can purpose be accomplished better in another way? Can operation be eliminated? Can operation be combined with another? Can operation be performed during idle period of another? Is sequence of operations the best possible?

**Design of Parts** Design should never be regarded as permanent. Experience has shown that practically every design can be improved. The analyst should consider the existing design to determine if it is possible to make improvements. In general, improvements can be made by (1) simplifying the design through reduction of the number of parts, (2) reducing the number of operations required to produce the design, (3) reducing the length of travel in the manufacture of the design, and (4) utilizing a better material in design.

**Tolerances and Specifications** These frequently can be liberalized to decrease unit costs without detrimental effects on quality; in other instances, they should be made more rigid to facilitate manufacturing and assembly operations. Tolerances and specifications must be investigated to ensure the use of an optimum process.

**Materials** Five considerations should be kept in mind relative to both the direct and the indirect material used in the process: (1) finding a less expensive material, (2) finding materials easier to process, (3) using materials more economically, (4) using salvage materials, and (5) using supplies and tools economically.

## 17-4 INDUSTRIAL ECONOMICS AND MANAGEMENT

**Process of Manufacture** Improvement in the process of manufacture is perhaps the salient point, and possible improvements deserving special consideration include (1) mechanizing manual operations, (2) utilizing more efficient facilities on mechanical operations, (3) operating mechanical facilities more efficiently, and (4) when changing an operation, considering the possible effects on subsequent operations. There are almost always many ways to produce a given design, and better production methods are continually being developed. By systematically questioning and investigating the manufacturing process, more effective methods will be developed.

**Setup and tools** have such a dominant influence on economics that consideration must include quantity to be produced, chance for repeat business, amount of labor involved, delivery requirements of the customer, and capital needed to develop the setup and provide the tools. Specifically, consideration should be given to reducing the setup time by better planning in production control, designing tooling for the full-capacity utilization of the production facility, and introducing more efficient tooling such as quick-acting clamps and multiple part orientations.

**Good working conditions** are an integral part of an optimum process as they improve the safety record, reduce absenteeism and tardiness, raise employee morale, improve public relations, and increase production. Consideration should include (1) improved lighting; (2) controlled temperature; (3) adequate ventilation; (4) sound control; (5) promotion of orderliness, cleanliness, and good housekeeping; (6) arrangement for immediate disposal of irritating and harmful dusts, fumes, gases, and fogs; (7) provision of guards at nip points and points of power transmission; (8) installation of personnel-protection equipment; and (9) sponsorship and enforcement of a well-formulated first aid and safety program.

**Materials Handling** The handling of materials is an essential part of each operation and frequently consumes the major share of the time. Materials handling adds nothing but cost to the product and increased throughput time. It should accordingly be reduced. When analyzing the flow process chart, keep in mind that the best-handled part is the least manually handled part. Whether distances of moves are large or small, points to be considered for reduction of time and energy spent in handling materials are (1) reduction of time spent in picking up material, (2) maximum use of mechanical handling equipment, (3) better use of existing handling facilities, (4) greater care in the handling of materials.

**Plant Layout** Good process design requires good **plant layout**. This involves development of the workplace so that the location of the equipment introduces low throughput time and maximum economy during the manufacturing process. In general, plant layouts represent one or a combination of (1) product, or straight-line, layouts, and (2) process, or functional, arrangements. In the **straight-line layout**, machinery is located so the flow from one operation to the next is minimized for any product class. To avoid temporary storages between facilities and excess in-processing inventories there needs to be a balance in the number of facilities of each type. **Process, or functional, layout** is the grouping of similar facilities, e.g., all turret lathes in one section, department, or building.

The principal advantage of **product grouping** is lower materials-handling costs since distances moved are minimized. The major disadvantages are:

1. Since a broad variety of occupations are represented in a small area, employee discontent can readily be fostered.
2. Unlike facilities grouped together result in operator training becoming more difficult since no experienced operator on a given facility may be located in the immediate area to train new employees.
3. The problem of finding competent supervisors is increased due to the variety of facilities and jobs to be supervised.
4. Greater initial investment is required because of duplicate service lines such as air, water, gas, oil, and power lines.
5. The arrangement of facilities tends to give a casual observer the thought that disorder prevails. Thus it is more difficult to promote good housekeeping.

In general, the disadvantages of product grouping are more than offset by the advantage of low handling cost and lower throughput time.

**Process, or functional, layout** gives an appearance of neatness and orderliness and, consequently, tends to promote good housekeeping; new workers can be trained more readily, and it is easier to obtain experienced supervision since the requirements of supervising like facilities are not so arduous. The obvious disadvantages of process grouping are the possibilities of long moves and of backtracking on jobs that require a series of operations on diversified facilities. In planning the process, important points to be considered are: (1) For straight-line mass production, material laid aside should be in position for the next operation. (2) For diversified production, the layout should permit short moves and deliveries and the material should be convenient to the operator. (3) For multiple-machine operations, equipment should be grouped around the operator. (4) For efficient stacking, storage areas should be arranged to minimize searching and rehandling. (5) For better worker efficiency, service centers should be located close to production areas. (6) Throughput time is always a major consideration. Scheduling should be well-planned so in-process inventory is kept to minimum levels yet is high enough so that production facilities are not shut down because of lack of material and throughput time is controlled.

**Principles of Motion Economy** The last of the primary approaches to process design is the analysis of the flow chart for the incorporation of basic principles of motion economy. When studying work performed at any work station, the engineer should ask: (1) Are both hands working at the same time and in opposite, symmetrical directions? (2) Is each hand going through as few motions as possible? (3) Is the workplace arranged so that long reaches are avoided? (4) Are both hands being used effectively, with neither being used as a holding device? In the event that "no" is the answer to any of these questions, then the work station should be altered to incorporate improvements related to motion economy. (See also Sec. 17.4, Methods Engineering.)

### JUST-IN-TIME TECHNIQUES, MANUFACTURING RESOURCE PLANNING, AND PRODUCTION CONTROL

Just-in-time techniques, developed by the Japanese as a procedure to control in-process inventories and lead to continual improvement, requires that parts for production be produced or delivered as they are needed. Typically, materials are delivered to the floor when they are expected to be needed according to some planned schedule. Often the difference in time between when parts are thought to be needed and when they are needed is substantial and inventory costs and throughput times can soar.

Manufacturing resource planning (MRP II) procedures recommend that materials be released to the factory floor at that time that the production control system indicates the shop should be ready to receive them.

Production control includes the scheduling of production; the dispatching of materials, tools, and supplies at the required time so that the predicted schedules can be realized; the follow-up of production orders to be sure that proposed schedules are realized; the maintenance of an adequate inventory to meet production requirements at optimum cost; and the maintenance of cost and manufacturing records to establish controls, estimating, and equipment replacement. Consideration must be given to the requirements of the customer, the available capacity, the nature of the work that precedes the production to be scheduled, and the nature of the work that succeeds the current work being scheduled. Centered in the production control effort should be an ongoing analysis to continually focus on any bottlenecks within the plant, since it is here where increases in throughput time take place.

**Scheduling** may be accomplished with various degrees of refinement. In low-production plants where the total number of hours required per unit of production is large, scheduling may adequately be done by departmental loading; e.g., if a department has a total of 10 direct-labor employees, it has 400 available work hours per week. Every new job is scheduled by departments giving consideration to the average number of available hours within the department. A refinement of this method is to schedule groups of facilities or sections, e.g., to schedule the milling

machine section as a group. In high-production plants, detailed facility scheduling frequently is necessary in order to ensure optimum results from all facilities. Thus, with an 8-hour shift, each facility is recorded as having 8 available hours, and work is scheduled to each piece of equipment indicating the time that it should arrive at the work station and the time that the work should be completed.

Scheduling is frequently done on control boards utilizing commercially available devices, such as *Productrol*, *Sched-U-Graph*, and *Visirol*. These, in effect, are mechanized versions of **Gantt charts**, where schedules are represented by paper strips cut to lengths equivalent to standard times. The strips are placed in the appropriate horizontal position adjacent to the particular order being worked; delays are conspicuously marked by red signals at the delay point. Manual posting to a ledger maintains projected schedules and cumulative loads. The digital computer is successfully used as a scheduling facility.

An adaptation of the Gantt chart, **PERT** (Program Evaluation and Review Techniques), has considerable application to project-oriented scheduling (as opposed to repetitive-type applications). This prognostic management planning and control method graphically portrays the optimum way to attain some predetermined objective, usually in terms of time. The **critical path** (CPM = Critical Path Method) consists of that sequence of events in which delay in the start or completion of any event in the sequence will cause a delay in the project completion.

In using PERT for scheduling, three time estimates are used for each activity, based upon the following questions: (1) What is the earliest time (optimistic) in which you can expect to complete this activity if everything works out ideally? (2) Under average conditions, what would be the most likely time duration for this activity? (3) What is the longest possible time (pessimistic) required to complete this activity if almost everything goes wrong? With these estimates, a probability distribution of the time required to perform the activity can be made (Fig. 17.1.2). The activity is started, and depending on how successfully events take place, the finish will occur somewhere between *a* and *b* (most likely close to *m*). The distribution closely approximates that of the beta distribution and is used as the typical model in PERT. The weighted linear approximation for the expected mean time, using probability theory, is given by

$$t_e = (a + 4m + b)/6$$

With the development of the project plan and the calculation of activity times (time for all jobs between successive nodes in the network, such as the time for "design of rocket ignition system"), a chain of

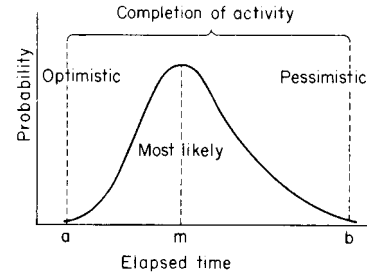

Fig. 17.1.2 Probability distribution of time required to perform an activity.

activities through the project plan can be established which has identical early and late event times; i.e., the completion time of each activity comprising this chain cannot be delayed without delaying project completion. These are the critical events.

**Events** are represented by nodes and are positions in time representing the start and/or completion of a particular activity. A number is assigned to each event for reference purposes.

Each operation is referred to as an **activity** and is shown as an arc on the diagram. Each arc, or activity, has attached to it a number representing the number of weeks required to complete the activity. Dummy activities, shown as a dotted line, utilize no time or cost and are used to maintain the correct sequence of activities.

The **time to complete** the entire project would correspond to the longest path from the initial node to the final node. In Fig. 17.1.3 the time to complete the project would be the longest path from node 1 to node 12. This longest path is termed the **critical path** since it establishes the minimum project time. There is at least one such chain through any given project. There can, of course, be more than one chain reflecting the minimum time. This is the concept behind the meaning of critical paths. The critical path method (CPM) as compared to PERT utilizes estimated times rather than the calculation of "most likely" times as previously referred to. Under CPM the analyst frequently will provide two time-cost estimates. One estimate would be for normal operation and the other could be for emergency operation. These two time estimates would reflect the impact of cost on quick-delivery techniques, i.e., the shorter the time the higher the cost, the longer the time the smaller the cost.

It should be evident that those activities that do not lie on the critical

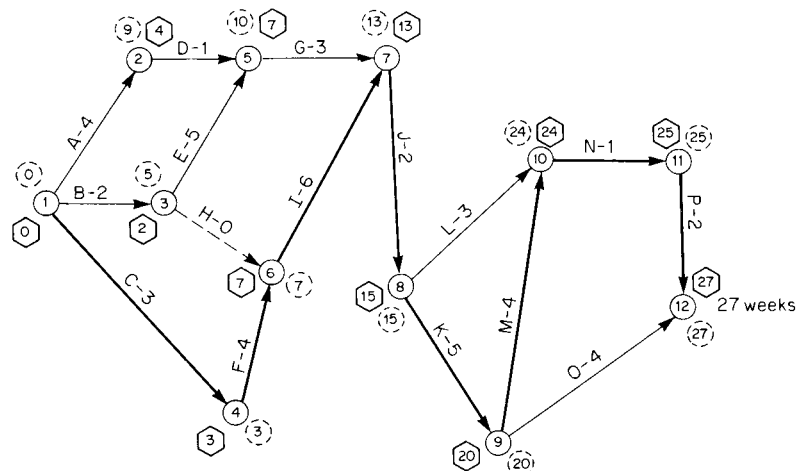

Fig. 17.1.3 Network showing critical path (heavy line). Code numbers within nodes signify events. Connecting lines with directional arrows indicate operations that are dependent on prerequisite operations. Time values on connecting lines represent normal time in weeks. Hexagonals associated with events show the earliest event time. Dotted circles associated with events present the latest event time.

## 17-6 INDUSTRIAL ECONOMICS AND MANAGEMENT

path have a certain flexibility. This amount of time flexibility or freedom is referred to as **float**. The amount of float is computed by subtracting the normal time from the time available. Thus the float is the amount of time that a noncritical activity can be lengthened without increasing the project's completion date.

Figure 17.1.3 illustrates an **elementary network portraying the critical path**. This path is identified by a heavy line and would include 27 weeks. There are several methods to shorten the project's duration. The cost of various time alternatives can be readily computed. For example, if the following cost table were developed, and assuming that a linear relation between the time and cost per week exists, the cost per week to improve delivery is shown.

Activities	Normal		Emergency	
	Weeks	Dollars	Weeks	Dollars
A	4	4000	2	6000
B	2	1200	1	2500
C	3	3600	2	4800
D	1	1000	0.5	1800
E	5	6000	3	8000
F	4	3200	3	5000
G	3	3000	2	5000
H	0	0	0	0
I	6	7200	4	8400
J	2	1600	1	2000
K	5	3000	3	4000
L	3	3000	2	4000
M	4	1600	3	2000
N	1	700	1	700
O	4	4400	2	6000
P	2	1600	1	2400

The **cost of various time alternatives** can be readily computed.

27-week schedule—Normal duration for project; cost = \$22,500

26-week schedule—The least expensive way to gain one week would be to reduce activity M or J for an additional cost of \$400; cost = \$22,900.

25-week schedule—The least expensive way to gain two weeks would be to reduce activities M and J (one week each) for an additional cost of \$800; cost = \$23,300.

24-week schedule—The least expensive way to gain three weeks would be to reduce activities M, J, and K (one week each) for an additional cost of \$1,300; cost = \$23,800.

23-week schedule—The least expensive way to gain four weeks would be to reduce activities M and J by one week each and activity K by two weeks for an additional cost of \$1,800; cost = \$24,300.

22-week schedule—The least expensive way to gain five weeks would be to reduce activities M and J by one week each and activity K by two weeks and activity I by one week for an additional cost of \$2,400; cost = \$24,900.

21-week schedule—The least expensive way to gain six weeks would be to reduce activities M and J by one week each and activities K and I by two weeks each for an additional cost of \$3,000; cost = \$25,500.

20-week schedule—The least expensive way to gain seven weeks would be to reduce activities M, J, and P by one week each and activities K and I by two weeks each for an additional cost of \$3,800; cost = \$26,300.

19-week schedule—The least expensive way to gain eight weeks would be to reduce activities M, J, P, and C by one week each and activities K and I by two weeks each for an additional cost of \$5,000; cost = \$27,500. (Note a second critical path is now developed through nodes 1, 3, 5, and 7.)

18-week schedule—The least expensive way to gain nine weeks would be to reduce activities M, J, P, C, E, and F by one week each and activities K and I by two weeks each for an additional cost of \$7,800; cost = \$30,000. (Note that by shortening time to 18 weeks, we develop a second critical path.)

## TOTAL QUALITY CONTROL

Total quality control implies the involvement of all members of an organization who can affect the quality of the output—a product or service. Its goal is to provide defect-free products 100 percent of the time, thus completely meeting the needs of the customer.

**ISO 9000** is a quality assurance management system that is rapidly becoming the world standard for quality. The ISO 9000 series standards are a set of four individual, but related, international standards on quality management and quality assurance with one set of application guidelines. The system incorporates a comprehensive review process covering how companies design, produce, install, inspect, package, and market products. As a series of technical standards, ISO 9000 provides a three-way balance between internal audits, corrective action, and corporate management participation leading to the successful implementation of sound quality procedures.

The series of technical standards include four divisions:

**ISO 9001** This is the broadest standard covering procedures from purchasing to service of the sold product.

**ISO 9002** This is targeted toward standards related to processes and the assignment of subcontractors.

**ISO 9003** These technical standards apply to final inspection and test.

**ISO 9004** These standards apply to quality management systems.

## CONTROL OF MATERIALS

Control of materials is critical to the smooth functioning of a plant. Raw materials and purchased parts must be on hand in the required quantities and at the time needed if production schedules are to be met. Unless management is speculating on raw materials, inventories should be at the lowest practicable level in order to minimize the capital invested and to reduce losses due to obsolescence, design changes, and deterioration. However, some minimum stock is essential if production is not to be delayed by lack of materials. The quantity for ordering replenishment stocks is determined by such factors as the lead time needed by the supplier, the reliability of the sources of supply in meeting promised delivery dates, the value of the materials, the cost of storage, and the risks of obsolescence or deterioration.

In many instances, plant management has the choice of manufacturing the components used in its product or procuring them from outside suppliers. Where suppliers specialize in certain components, they may be able to reach high-volume operations and produce more economically than can the individual users. Procurement from outside suppliers simplifies the manufacturing problem within a plant and permits management to concentrate on the phases where it has critical know-how. Extreme quality specifications may preclude the use of outside suppliers. Likewise, if components are in short supply, the user may be forced to manufacture the units to ensure an adequate supply.

The control of raw materials and component parts may involve considerable clerical detail and many critical decisions. Systems and formulas will routinize this function, and the computer has been able to eliminate all of the arithmetic and clerical activities in those plants that make use of its capability.

Shrinkage throughout the manufacturing process may be a significant factor in materials control, scheduling, and dispatching. Spoilage rates at various stages in the process require that excess quantities of raw materials and component parts be started into the process in order to produce the quantity of finished product desired. If the original order has not allowed for spoilage, supplementary orders will be necessary; these are usually on a rush basis and may seriously disrupt the plant schedule.

**Production control** seeks optimum lot sizes with minimum total cost and adequate inventory. Figure 17.1.4 shows the time pattern, under an ideal situation, for active inventory. With assumed fixed cost per unit of output (except for starting and storage costs) and with zero minimum inventory, the optimum lot size  $Q$  is given by  $\sqrt{ah/B}$ , where  $B$  = factor when storage space is reserved for maximum inventory =

$0.5[1 - (d/r)](2s + ip)$ ;  $h$  = starting cost per lot (planning and setup);  $a$  = annual demand;  $s$  = annual cost of storage per unit of product;  $i$  = required yield on working capital;  $p$  = unit cost of production;  $d$  = daily demand; and  $r$  = daily rate of production during production period.

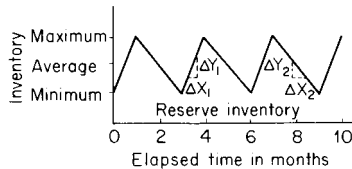

Fig. 17.1.4 Inventory time pattern.  $\Delta Y_1/\Delta X_1$  = rate of increase of inventory.  $\Delta Y_2/\Delta X_2$  = rate of decrease of inventory.

### STRATEGIC ECONOMIC EVALUATIONS

New equipment or facilities may be acquired for a variety of reasons: (1) Existing machines may be so badly worn that they are either beyond repair or excessively costly to maintain. (2) The equipment may be incapable of holding specified quality tolerances. (3) A technical development may introduce a process producing higher-quality products. (4) Changes in the product line may require new kinds of machines. (5) An improved model which reduces operating costs, especially power costs, may come on the market.

A decision to invest in new capital equipment involves the risk that improved models of machines may become available and render the new equipment obsolete before its mechanical life has expired. Aggressive competitors who regularly modernize their plants may force other companies to adopt a similar policy. The **paramount question** on strategic manufacturing expenditures is: Will it pay? Asking this question usually involves the consideration of alternatives. In comparing the economy of alternatives it is important that the engineer understand the concept of return on investment. Let:

- $i$  = interest rate per period
- $n$  = number of interest periods
- $C$  = cash receipts
- $D$  = cash payments
- $P$  = present worth at the beginning of  $n$  periods
- $S$  = lump sum of money at the end of  $n$  periods
- $R$  = an end-of-period payment or receipt in a uniform series continuing for  $n$  periods. The present value of the sum of the entire series at interest rate  $i$  is equal to  $P$ .

Thus, \$1  $n$  years from now =  $1/(1 + i)^n$

$$P = \frac{C_0 - D_0}{(1 + i)^0} + \frac{C_1 - D_1}{(1 + i)^1} + \frac{C_2 - D_2}{(1 + i)^2} \dots \frac{C_n - D_n}{(1 + i)^n}$$

Then:

$$S = P(1 + i)^n \quad \text{single payment}$$

$$P = S \frac{1}{(1 + i)^n} \quad \text{single payment}$$

$$R = S \frac{i}{(1 + i)^n - 1} \quad \text{uniform series, sinking fund}$$

$$R = P \frac{i(1 + i)^n}{(1 + i)^n - 1} \quad \text{uniform series, capital recovery}$$

$$S = R \frac{(1 + i)^n - 1}{i} \quad \text{uniform series, compound amount}$$

$$P = R \frac{(1 + i)^n - 1}{i(1 + i)^n} \quad \text{uniform series, present worth}$$

For example, a new-type power-lift truck is being contemplated in the receiving department in order to reduce hand labor on a particular product line. The annual cost of this labor and labor extras such as social

security taxes, industrial accident insurance, paid vacations, and various employees' fringe benefits are \$16,800 at present. An alternative proposal is to procure the new power equipment at a first cost of \$20,000. It is expected that this equipment will reduce the annual cost of the hand labor to \$6,900. Annual payments to utilize the new equipment include power (\$700); maintenance (\$2,400); and insurance (\$400).

It has been estimated that the need for this particular operation will continue for at least the next 8 years and that equipment will have no salvage value at the end of the life of this product line. Management requires a 15 percent rate of return before income taxes.

Since the burden of proof is on the proposed investment, its cost will include the 15 percent rate of return in the equivalent uniform annual cost of capital recovery. This computation assures that if the new method is adopted the savings will be at least as much before taxes as 15 percent per year.

The following is a **comparison of annual cost** of the present and proposed methods.

The **uniform equivalent cost** of the proposed method shows that nearly \$2,000 per year is saved in addition to the required minimum of 15 percent already included as a cost of investing in the new power-lift truck. Clearly the proposed plan is more economical.

<u>Present Method</u>	
Labor + labor extras =	\$16,800
Total annual cost of the present method =	\$16,800.00
<u>Proposed Method</u>	
Equivalent uniform annual cost of capital recovery =	$(\$20,000)(0.15)(1 + 0.15)^8 = 20,000 \times 0.22285 = \$4,457.00$
Labor and labor extras	\$6,900.00
Power	700.00
Maintenance	2,400.00
Insurance	400.00
Total uniform equivalent annual cost of proposed method	\$14,857.00

### OPTIMIZATION TECHNIQUES

It is important that modern management be trained in the various **decision-making processes**. Judgment by itself will not always provide the best answer. The various decision-making processes are based on theory of probability, statistical analysis, and engineering economy.

Decision making under **certainty** assumes the states of the product or market are known at a given time. Usually the decision-making strategy under certainty would be based on that alternative that maximizes if we are seeking quality, profit, etc., and that minimizes if we are studying scrap, customer complaints, etc. The several alternatives are compared as to the results for a particular state (quantity, hours of service, anticipated life, etc.). Usually decisions are not made under an assumed certainty. Often **risk** is involved in providing a future state of the market or product. If several possible states of a market prevail, a probability value is assigned to each state. Then a logical decision-making strategy would be to calculate the expected return under each decision alternative and to select the largest value if we are maximizing or the smallest value if we are minimizing. Here

$$E(a) = \sum_{j=1}^n p_j c_{ij}$$

where  $E(a)$  = expected value of the alternative;  $p_j$  = probability of each state of product or market occurring;  $c_{ij}$  = outcome for particular alternative  $i$  at a state of product or market  $j$ .

A different decision-making strategy would be to consider the state of the market that has the greatest chance of occurring. Then the alternative, based upon the **most probable future**, would be that one that is either a maximum or minimum for that particular state.

A third decision-making strategy under risk would be based upon a **level of aspiration**. Here the decision maker assigns an outcome value  $c_{ij}$  which represents the consequence she or he is willing to settle for if it is reasonably certain that this consequence or better will be achieved most

17-8 INDUSTRIAL ECONOMICS AND MANAGEMENT

of the time. This assigned value may be referred to as representing a level of aspiration which can be identified as *A*. Now the probability for each  $a_j$  where the  $c_{ij}$  (each decision alternative) is equal or greater to *A* is determined. The alternative with the greatest  $p(c_{ij} \geq A)$  is selected if we are maximizing.

There are other decision-making strategies based on decision under risk and uncertainty. The above examples provide the reader the desirability of considering several alternatives with respect to the different states of the product or market.

**Linear Programming**

At the heart of management's responsibility is the best or optimum use of limited resources including money, personnel, materials, facilities, and time. Linear programming, a mathematical technique, permits determination of the best use which can be made of available resources. It provides a systematic and efficient procedure which can be used as a guide in decision making.

As an example, imagine the simple problem of a small machine shop that manufactures two models, standard and deluxe. Each standard model requires 2 h of grinding and 4 h of polishing. Each deluxe model requires 5 h of grinding and 2 h of polishing. The manufacturer has three grinders and two polishers; therefore, in a 40-h week there are 120 h of grinding capacity and 80 h of polishing capacity. There is a profit of \$3 on each standard model and \$4 on each deluxe model and a ready market for both models. The management must decide on: (1) the allocation of the available production capacity to standard and deluxe models and (2) the number of units of each model in order to maximize profit.

To solve this linear programming problem, the symbol *X* is assigned to the number of standard models and *Y* to the number of deluxe models. The profit from making *X* standard models and *Y* deluxe models is  $3X + 4Y$  dollars. The term *profit* refers to the **profit contribution**, also referred to as **contribution margin** or **marginal income**. The profit contribution per unit is the selling price per unit less the unit variable cost. Total contribution is the per-unit contribution multiplied by the number of units.

The restrictions on machine capacity are expressed in this manner: To manufacture one standard unit requires 2 h of grinding time, so that making *X* standard models uses  $2X$  h. Similarly, the production of *Y* deluxe models uses  $5Y$  h of grinding time. With 120 h of grinding time available, the grinding capacity is written as follows:  $2X + 5Y \leq 120$  h of grinding capacity per week. The limitation on polishing capacity is expressed as follows:  $4X + 2Y \leq 80$  h per week. In summary, the basic information is:

	Grinding time	Polishing time	Profit contribution
Standard model	2 h	4 h	\$3
Deluxe model	5 h	2 h	4
Plant capacity	120 h	80 h	

Two basic linear programming techniques, the graphic method and the simplex method, are described and illustrated using the above capacity-allocation-profit-contribution maximization data.

**Graphic Method**

Operations	Hours available	Hours required per model		Maximum number of models	
		Standard	Deluxe	Standard	Deluxe
Grinding	120	2	5	$\frac{120}{2} = 60$	$\frac{120}{5} = 24$
Polishing	80	4	2	$\frac{80}{4} = 20$	$\frac{80}{2} = 40$

The lowest number in each of the two columns at the extreme right measures the impact of the hours limitations. The company can produce 20 standard models with a profit contribution of \$60 ( $20 \times \$3$ ) or 24 deluxe models at a profit contribution of \$96 ( $24 \times \$4$ ). Is there a better solution?

To determine production levels in order to maximize the profit contribution of  $\$3X + \$4Y$  when:

$$\begin{aligned} 2X + 5Y &\leq 120 \text{ h} && \text{grinding constraint} \\ 4X + 2Y &\leq 80 \text{ h} && \text{polishing constraint} \end{aligned}$$

a graph (Fig. 17.1.5) is drawn with the constraints shown. The two-dimensional graphic technique is limited to problems having only two variables—in this example, standard and deluxe models. However, more than two constraints can be considered, although this case uses only two, grinding and polishing.

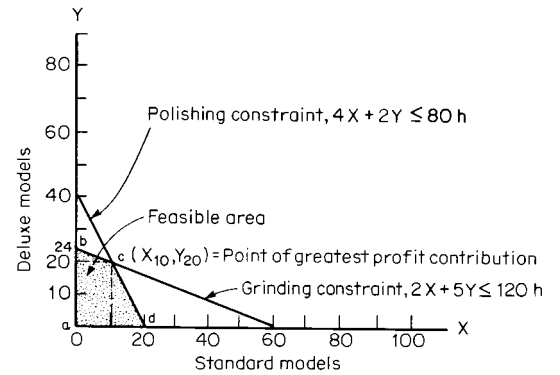

Fig. 17.1.5 Graph depicting feasible solution.

The **constraints** define the solution space when they are sketched on the graph. The solution space, representing the area of feasible solutions, is bounded by the corner points *a*, *b*, *c*, and *d* on the graph. Any combination of standard and deluxe units that falls within the solution space is a feasible solution. However, the **best** feasible solution, according to mathematical laws, is in this case found at one of the corner points. Consequently, all corner-point variables must be tried to find the combination which maximizes the profit contribution:  $\$3X + \$4Y$ .

Trying values at each of the corner points:

- a* = ( $X = 0, Y = 0$ );  $\$3 ( 0 ) + \$4 ( 0 ) = \$ 0$  profit
- b* = ( $X = 0, Y = 24$ );  $\$3 ( 0 ) + \$4 ( 24 ) = \$ 96$  profit
- c* = ( $X = 10, Y = 20$ );  $\$3 ( 10 ) + \$4 ( 20 ) = \$110$  profit
- d* = ( $X = 20, Y = 0$ );  $\$3 ( 20 ) + \$4 ( 0 ) = \$ 60$  profit

Therefore, in order to maximize profit the plant should schedule 10 standard models and 20 deluxe models.

**Simplex Method** The simplex method is considered one of the basic techniques from which many linear programming techniques are directly or indirectly derived. The method uses an iterative, stepwise process which approaches an optimum solution in order to reach an objective function of maximization (for profit) or minimization (for cost). The pertinent data are recorded in a tabular form known as the **simplex tableau**. The components of the tableau are as follows (see Table 17.1.1):

The **objective row** of the matrix consists of the coefficients of the objective function, which is the profit contribution per unit of each of the products.

The **variable row** has the names of the variables of the problem including slack variables. **Slack variables**  $S_1$  and  $S_2$  are introduced in order to transform the set of inequalities into a set of equations. The use of slack variables involves simply the addition of an arbitrary variable to one side of the inequality, transforming it into an equality. This arbitrary variable is called **slack variable**, since it takes up the slack in the inequality. The simplex method requires the use of equations, in contrast to the inequalities used by the graphic method.



The **problem rows** contain the coefficients of the equations which represent constraints upon the satisfaction of the objective function. Each constraint equation adds an additional problem row.

The **objective column** receives different entries at each iteration, representing the profit per unit of the variables. In this first tableau (the only one illustrated due to space limitations) zeros are listed because they are the coefficients of the slack variables of the objective function. This column indicates that at the very beginning every  $S_n$  has a net worth of zero profit.

The **variable column** receives different notations at each iteration by replacement. These notations are the variables used to find the profit contribution of the particular iteration. In this first matrix a situation of no (zero) production is considered. For this reason, zeros are marked in the objective column and the slacks are recorded in the variable column. As the iterations proceed, by replacements, appropriate values and notations will be entered in these two columns, objective and variable.

The **quantity column** shows the constant values of the constraint equations.

Based on the data used in the graphic method and with a knowledge of the basic components of the simplex tableau, the first matrix can now be set up.

Letting  $X$  and  $Y$  be respectively the number of items of the standard model and the deluxe model that are to be manufactured, the system of inequalities or the set of constraint equations is

$$\begin{aligned} 2X + 5Y &\leq 120 \\ 4X + 2Y &\leq 80 \end{aligned}$$

in which both  $X$  and  $Y$  must be positive values or zero ( $X \geq 0$ ;  $Y \geq 0$ ) for this problem.

The objective function is  $3X + 4Y = P$ ; these two steps were the same for the graphic method.

The set of inequalities used by the graphic method must next be transformed into a set of equations by the use of slack variables. The inequalities rewritten as equalities are

$$\begin{aligned} 2X + 5Y + S_1 &= 120 \\ 4X + 2Y + S_2 &= 80 \end{aligned}$$

and the objective function becomes

$$3X + 4Y + 0S_1 + 0S_2 = P \quad \text{to be maximized}$$

The first tableau with the first solution would then appear as shown in Table 17.1.1.

The tableau carries also the first solution which is shown in the **index row**. The index row carries values computed by the following steps:

1. Multiply the values of the quantity column and those columns to the right of the quantity column by the corresponding value, by rows, of the objective column.
  2. Add the results of the products by column of the matrix.
  3. Subtract the values in the objective row from the results in step 2.
- For this operation the objective row is assumed to have a zero value in the quantity column. By convention the profit contribution entered in the cell lying in the quantity column and in the index row is zero, a condition valid only for the first tableau; in the subsequent matrices it will be a positive value.

Index row:

Steps 1 and 2:	Step 3:
$120(0) + 80(0) = 0$	$0 - 0 = 0$
$2(0) + 4(0) = 0$	$0 - 3 = -3$
$5(0) + 2(0) = 0$	$0 - 4 = -4$
$1(0) + 0(0) = 0$	$0 - 0 = 0$
$0(0) + 1(0) = 0$	$0 - 0 = 0$

In this first tableau the slack variables were introduced into the product mix, variable column, to find a *feasible* solution to the problem. It can be proven mathematically that beginning with slack variables assures a feasible solution. One possible solution might have  $S_1$  take a value of 120 and  $S_2$  a value of 80. This approach satisfies the constraint equation but is undesirable since the resulting profit is zero.

It is a rule of the simplex method that the optimum solution has not been reached if the index row carries any negative values at the completion of an iteration in a maximization problem. Consequently, this first tableau does not carry the optimum solution since negative values appear in its index row. A second tableau or matrix must now be prepared, step by step, according to the rules of the simplex method.

**Duality of Linear Programming Problems and the Problem of Shadow Prices** Every linear programming problem has associated with it another linear programming problem called its **dual**. This duality relationship states that for every maximization (or minimization) problem in linear programming, there is a unique, similar problem of minimization (or maximization) involving the same data which describe the original problem. The possibility of solving any linear programming problem by starting from two different points of view offers considerable advantage. The two paired problems are defined as the dual problems because both are formed by the same set of data, although differently arranged in their mathematical presentation. Either can be considered to be the **primal**; consequently the other becomes its dual.

**Shadow prices** are the values assigned to one unit of capacity and represent economic values per unit of scarce resources involved in the restrictions of a linear programming problem. To maximize or minimize the total value of the total output it is necessary to assign a quantity of unit values to each input. These quantities, as cost coefficients in the dual, take the name of "shadow prices," "accounting prices," "fictitious prices," or "imputed prices" (values). They indicate the amount by which total profits would be increased if the producing division could increase its productive capacity by a unit. The shadow prices, expressed by monetary units (dollars) per unit of each element, represent the least cost of any extra unit of the element under consideration, in other words, a kind of marginal cost. The real use of shadow prices (or values) is for management's evaluation of the manufacturing process.

### Queuing Theory

Queuing theory or **waiting-line** theory problems involve the matching of servers, who provide, to randomly arriving customers, services which take random amounts of time. Typical questions addressed by queuing theory studies are: how long does the average customer wait before being waited on and how many servers are needed to assure that only a given fraction of customers waits longer than a given amount of time.

In the typical problem applicable to queuing theory solution, people

Table 17.1.1 First Simplex Tableau and First Solution

	Mix	0	3	4	0	0	Objective row
		Quantity	$X$	$Y$	$S_1$	$S_2$	Variable row
0	$S_1$	120	2	5	1	0	Problem rows
0	$S_2$	80	4	2	0	1	
		0	-3	-4	0	0	Index row
Objective column	Variable column	Quantity column					

## 17-10 INDUSTRIAL ECONOMICS AND MANAGEMENT

(or customers or parts) arrive at a server (or machine) and wait in line (in a queue) until service is rendered. There may be one or more servers. On completion of the service, the person leaves the system. The rate at which people arrive to be serviced is often considered to be a random variable with a Poisson distribution having a parameter  $\lambda$ . The average rate at which services can be provided is also generally a Poisson distribution with a parameter  $\mu$ . The symbol  $k$  is often used to indicate the number of servers.

### Monte Carlo

Monte Carlo simulation can be a helpful method in gaining insight to problems where the system under study is too complex to describe or the model which has been developed to represent the system does not lend itself to an analytical solution by other mathematical techniques. Briefly, the method involves building a mathematical model of the system to be studied which calculates results based on the input variables, or **parameters**. In general the variables are of two kinds: decision parameters, which represent variables which the analyst can choose, and stochastic, or random, variables, which may take on a range of values and which the analyst cannot control.

The random variables are selected from specially prepared probability tables which give the probability that the variable will have a particular value. All the random variables must be independent. That means that the probability distribution of each variable is **independent** of the values chosen for the others. If there is any correlation between the random variables, that correlation will have to be built into the system model.

For example, in a model of a business situation where market share is to be calculated, a decision-type variable representing selling price can be selected by the analyst. A variable for the price of the competitive product can be randomly selected. Another random variable for the rate of change of market share can also be randomly selected. The purpose of the model is to use these variables to calculate a market share suitable to those market conditions. The algebra of the model will take the effects of all the variables into account. Since the rate-of-change variable can take many values which cannot be accurately predicted, as can the competitive price variable, many runs will be made with different randomly selected values for the random variables. Consequently a range of probable answers will be obtained. This is usually in the form of a **histogram**. A histogram is a graph, or table, showing values of the output and the probability that those values will occur. The results, when translated into words, are expressed in the typical Monte Carlo form of: if such a price is chosen, the following probability distribution of market shares is to be expected.

### WAGE ADMINISTRATION

Workers are compensated for their efforts in two principal ways: by hourly rates and by financial-type incentives. An hourly rate is paid to the worker for the number of hours worked and usually is not dependent upon the quantity or quality of the worker's output. Each worker is assigned a job title depending upon qualifications, experience, and skill. Under a structured system of wages, jobs are grouped into classifications, and a similar range of rates is applied to all jobs in a classification. The bottom of the range is paid to beginners, and periodic increases to the top of the range may be automatic or may depend upon the supervisor's appraisal of the individual's performance.

**Job evaluation** is a formal system for ranking jobs in classes. Each job is studied in relation to other jobs by analyzing such factors as responsibility, education, mental skill, manual skill, physical effort, and working conditions. A total numerical rating for job comparison is obtained by assigning points for each factor.

**Merit rating** is a point-scale evaluation of an individual's performance by a supervisor, considering such factors as quantity of output, quality of work, adaptability, dependability, ability to work with others, and attitude. These ratings serve as criteria for pay increases within a job classification.

The general level of hourly rates, or base rates, for a company should be determined with reference to the community level of rates. "Going rates" for the community are obtained from wage surveys conducted by the company, a local trade group, or a government agency. Generally, a company which offers wages noticeably lower than the community rates will attract less-competent and less-permanent employees.

Under **financial-type incentives**—or **piece rates**, as they are commonly called—the worker's compensation is dependent upon his or her rate of output. Ordinarily, there is a minimum hourly guarantee below which pay will not decline. Penalties for substandard work may reduce the worker's pay. In some instances, a maximum for incentive earnings is established. The incentive may be calculated so that only the individual's output affects his pay, or when the individual's output cannot be measured, a **group incentive** may be paid, where the pay of each member of the group is determined by his or her base rate plus the output of the group. Group incentives tend to promote cooperation among workers. The administration of incentive plans requires careful management attention if abuses are to be avoided. Restrictions on output and deteriorated standards may lead to higher unit labor costs rather than the anticipated lower costs.

**Gainsharing plans** are becoming increasingly popular in labor-intensive industries as an additive means of compensation in piecework systems. Gainsharing measures and rewards employees for those facets of the business they can influence. Thus, gainsharing rewards are based on some measure of productivity differing from profit-sharing which uses a more global measure of profitability.

**Improshare** gainsharing plans measure performance rather than dollar savings. They are based on engineered standards and are not affected by changes in sales volume, technology, or capital expenditures. Productivity generally is measured on a departmental basis where gains above a predetermined efficiency are shared according to formulas which allocate a portion of the gains to the individual department and a portion to the total plant group and a portion to the company; it is not unusual to share 40 percent of the gains to the department, 20 percent to the plant group, and 40 percent to the company. The theory is to measure and reward each department and also to achieve recognition that "we are all in this together." The base, where gains commence, usually is computed from actual department performances over a period of time such as 1 year. Gainsharing rewards are usually distributed monthly as an additive to piecework plans. In addition to financial participation, gainsharing plans offer:

1. The ability to see the outcome of high performance of work in monetary terms.
2. A means to increase employees' commitment and loyalty.
3. Group rewards that lead to cohesion and peer pressure.
4. An enlargement of jobs that encourages initiative and ingenuity.
5. Expanded communication resulting in the enhancement of teamwork.

A **profit-sharing plan** is a form of group incentive whereby each participating worker receives a periodic bonus in addition to regular pay, provided the company earns a profit. A minimum profit is usually set aside for a return on invested capital, and beyond this amount a percentage of profits goes into a pool to be shared by the employees. Many factors other than worker productivity affect profits, e.g., fluctuations in sales volume, selling prices, and costs of raw materials and purchased parts. To protect the workers against adverse developments outside their control, some plans give the workers a bonus whenever the actual payroll dollars are less than the normal amount expected for a given volume of production. Bonuses may be distributed quarterly or even annually and may consequently be less encouraging than incentives paid weekly and related directly to output.

### EMPLOYEE RELATIONS

Increasingly, management deals with collective bargaining units in setting conditions of work, hours of work, wages, seniority, vacations, and the like. The bargaining unit may be affiliated with a national union or may be independent and limited to the employees of a particular plant.

A union contract is usually negotiated annually, although managements have sought longer-term agreements. Some managements have negotiated contracts covering a 3- to 5-year period. Under these contracts, the union frequently reserves the right to reopen the wage clauses annually. Today a more conciliatory atmosphere exists in connection with union-management relations.

**Grievance procedures** facilitate the processing of minor day-to-day disputes between workers and management. Grievances most commonly occur when the worker:

1. Thinks he or she is unfairly treated in matters of (a) pay rates and/or time standards, (b) promotion, (c) work assignment, (d) distribution of overtime, (e) seniority, or (f) disciplinary action.
2. Believes he or she is handicapped by (a) lack of clear policies or working rules; (b) inadequate supervision; (c) too many bosses; (d) supervisors who play favorites; (e) coworkers who are careless, inefficient, or uncooperative; or (f) lack of opportunity to show his or her ability.
3. Is dissatisfied with (a) general job conveniences (e.g., washrooms), (b) working conditions (e.g., light), (c) equipment and tools, (d) plant or office setup (e.g., working space), or (e) protection against job hazards and accidents.

A union steward acts as the employee's representative in discussing a complaint with the supervisor. If a settlement cannot be reached, the discussion may move to the general superintendent's level; the personnel manager is often involved at the various stages. Ways to reduce employee grievances are:

1. Make employees feel accepted; give them a sense of "belonging."
2. Make employees feel significant; give them recognition as people.
3. Make employees feel safe as to (a) job security, and (b) suitable working conditions.
4. Let employee experience the help of leadership.
5. Increase employees' knowledge about (a) the company, (b) its product(s), (c) their jobs, and (d) their next jobs.
6. Give employees fair and impartial treatment.
7. Give employees a chance to be heard: (a) Ask them for suggestions; acknowledge these suggestions; use where practicable and give credit. (b) Encourage them to discuss their problems and gripes; follow through if and as needed.
8. Aid employees to make their contribution to the solution of their problems.
9. Assist employees to develop pride in their work.
10. Recognize employees' status.

An outside arbitrator may be helpful when all internal grievance procedures have been exhausted.

**Selection of workers** must give attention to the suitability of applicants as well as their previous training. Interviewing and tests for qualities required on the job are necessary for good placement. **Preemployment testing** has proven to be helpful in developing a faster-learning, more

disciplined, more quality-conscious, and more productive work force. General aptitude testing in the areas of general learning, verbal comprehension, numerical skills, spatial perception, form perception, clerical perception, motor coordination, finger dexterity, and manual dexterity provide helpful information in the evaluation of an applicant for any job. For example, the attributes of motor coordination, finger dexterity, and manual dexterity have been found to be fundamental in such jobs as sewing, fine assembly, and precision machining. Induction and instruction of new workers are equally important and should not be a secondary task of a busy supervisor; they may be a responsibility of the personnel manager, a member of the training staff, or of a sub-supervisor. Induction includes an orientation to the total plant operations as well as to the duties of the specific job; introduction to the supervisor, sub-supervisor, and coworkers; and an explanation of the employee's relations with the personnel department and with employee committees or groups that deal with management.

**Promotions** and recognition of accomplishment profoundly affect morale and require constant supervision by the personnel manager and the line managers. Training programs are used to prepare workers and apprentices for advancement; formal training programs for supervisors are used to develop the capabilities of members of management. The training sessions may be organized and conducted under the personnel manager, training staff member(s), or outside specialists.

Federal law and state laws in most states prohibit **discrimination** because of race, color, religion, age, sex, or national origin by most businesses and labor organizations. The EEOC (Equal Employment Opportunity Commission) polices these activities.

**Quality circles**, sometimes referred to as *employee participation groups*, are small intact work groups formed in an organization for the purpose of continuous improvement in product quality, productivity, and overall employee performance. Quality circles can be thought of as a process of organizational development based on a management philosophy of employee involvement leading to continuous improvement. This philosophy includes establishing a work climate that promotes the concept that, for the most part, accomplishments are dependent on development and utilization of the potential of the organization's human resources. To successfully utilize quality circles, it is important that both management and union officials become involved in administering the concept and in identifying training needs. Training that should be provided should extend beyond the quality circle members. In addition, upper-level and middle management as well as line supervision and staff support personnel should receive instruction as to the mission, goals, feedback, rewards, and support of the proposed quality circles. In order for quality circles to be successful, the following skills must be utilized regularly: information and data collection, problem analysis and solution, decision making, group dynamics, and communication. Quality circle programs should include a usable measure, such as statistical quality control, to help identify problems and to keep track of performance.

## 17.2 COST ACCOUNTING

by Scott Jones

REFERENCES: Horngren and Foster, "Cost Accounting—A Managerial Emphasis," Prentice-Hall. Anthony, Dearden, and Govindarajan, "Management Control Systems," Irwin. Cooper and Kaplan, "The Design of Cost Management Systems—Text, Cases, and Readings," Prentice-Hall.

### ROLE AND PURPOSE OF COST ACCOUNTING

Cost measurements and reporting procedures are integral components of management information systems, providing financial measurements

of economic value and reports useful to many and varied objectives. In a functional organization, where lines of authority are drawn between engineering, production, marketing, finance, and so on, cost accounting information is primarily used by managers for control in guiding departmental units toward the attainment of specific organizational goals. In team-oriented organizations, authority is distributed to multifunctional teams empowered as a group to make decisions. The focus of cost accounting in this organizational structure is not so much on control, but on supporting decisions through the collection of relevant information

## 17-12 COST ACCOUNTING

for decision making. Cost accounting also provides insight for the attainment of competitive advantage by providing an information set and analytical framework useful for the analysis of product or process design, or service delivery alternatives.

The basic purpose of cost measurements and reporting procedures can be organized into a few fundamental areas. These are: (1) identifying and measuring the economic value to be placed on goods and services for reporting periodic results to external information users (creditors, stockholders, and regulators); (2) providing control frameworks for the implementation of specific organizational objectives; (3) supporting operational and strategic decision making aimed at achieving and sustaining competitive advantage.

### MEASURING AND REPORTING COSTS TO STOCKHOLDERS

Accounting in general and cost accounting in particular are most visible to the general public in the role of **external reporting**. In this role, cost accounting is geared toward measuring and reporting periodic results, typically annual, to users outside of the company such as stockholders, creditors, and regulators. The annual report presents to these users management forecasts for the coming period and results of past years operations as reflected in **general-purpose financial statements**. (See also Sec. 17.1, "Industrial Economics and Management.") Performance is usually captured through the presentation of three reports: the income statement, the balance sheet, and the statement of cash flows (see Fig. 17.2.1). These statements are audited by independent certified public accountants who attest that the results reported present a fair picture of the financial position of the company and that prescribed rules have been followed in preparing the reports. The accounting principles and procedures that guide the preparation of those reports are governed by **generally accepted accounting principles (GAAP)**.

The underlying principles that guide GAAP financial statements encourage comparability among companies and across time. Therefore, these rules are usually too constraining for reports destined for internal use. External reports such as the balance sheet and income statement are prepared on the **accrual basis**. Under this basis, revenues are recognized (reported to stockholders) when earned, likewise costs are expensed against (matched with) revenue when incurred. This is to be contrasted with the **cash basis**, which recognizes revenues and expenses when cash is collected or paid. For example, if a drill press is purchased for use in the factory, a cash outflow occurs when the item is paid for. The cash basis would recognize the purchase price of the drill press as an expense when the payment is made. On the other hand, the accrual basis of accounting would capitalize the price paid, and this amount would be the cost (or basis) of the asset called *drill press*. In accrual accounting, an asset is something having future economic benefit, and therefore the cost of this asset must be distributed among the periods of time when it is used to generate revenue. The cost of the drill press would be expensed periodically by deducting a small amount of that cost from revenue as the drill press is used over its economic life, which may be several years. This periodic charge is called *depreciation*. To capture the effects that revenue-generating activities have on cash, GAAP financial statements also include the statement of cash flows. The statement of cash flows is not prepared on an accrual basis; rather, it reflects the amount of cash flowing into a company during a period, as well as the cash outflow. The first section of that statement, "Cash flows from operating activities," is essentially an income statement prepared on the cash basis.

Another application of cost accounting measurements for external users involves the preparation of reports such as income tax returns for governmental agencies. Federal, state, and local tax authorities prescribe specific accounting procedures to be applied in determining taxable income. These rules are conceptually similar to general-purpose financial reporting but differ mainly in technical aspects of the computations, which are modified to support whatever public finance goals may exist for a particular period. Whereas GAAP financial statements allow for the analysis of credit and investment opportunities, Internal

Revenue Service regulations are designed to raise revenue, stimulate the economy, or both. Regulations in effect at the time of writing were primarily aimed at reducing the burgeoning federal deficit and hence assigned rather long "useful lives" to depreciable assets; at other times in history useful lives were shortened to stimulate investment and economic growth. An example of how the IRS regulations could differ from GAAP can be illustrated in determining the useful life of a drill press. For GAAP, the drill press would be an asset, and may be estimated as depreciable over a wide range of economic lives. The IRS would also view the drill press to be a depreciable asset, but consider the class life to be 9.5 years if used in the manufacture of automobiles, or 8 years in the manufacture of aerospace products. For practicality, many companies will follow the IRS Code when determining useful life for GAAP, though this practice is generally not required.

### CLASSIFICATIONS OF COSTS

The purposes of cost accounting require classifications of costs so that they are recognized (1) by the nature of the item (a natural classification), (2) in their relation to the product, (3) with respect to the accounting period to which they apply, (4) in their tendency to vary with volume or activity, (5) in their relation to departments, (6) for control and analysis, and (7) for planning and decision making.

Direct material and direct labor may be listed among the items which have a **variable** nature. Factory overhead, however, must be carefully examined with regard to items of a variable and a fixed nature. It is impossible to budget and control factory-overhead items successfully without regard to their tendency to be fixed or variable; the division is a necessary prerequisite to successful budgeting and intelligent cost planning and analysis.

In general, **variable expenses** show the following characteristics: (1) variability of total amount in direct proportion to volume, (2) comparatively constant cost per unit or product in the face of changing volume, (3) easy and reasonably accurate assignments to operating departments, and (4) incurrence controllable by the responsible department head.

The characteristics of **fixed expenses** are (1) fixed amount within a relative output range, (2) decrease of fixed cost per unit with increased output, (3) assignment to departments often made by managerial decisions or cost-allocation methods, and (4) control for incurrence resting with top management rather than departmental supervisors. Whether an expense is classified as fixed or variable may well be the result of managerial decisions.

Some **factory overhead** items are semivariable in nature; i.e., they vary with production but not in direct proportion to the volume. For practical purposes, it is desirable to resolve each semivariable expense item into its variable and fixed components.

A factory is generally organized along departmental lines for production purposes. This factory departmentalization is the basis for the important classification and subsequent accumulation of costs by departments to achieve (1) cost control and (2) accurate costing. The departments of a company generally fall into two categories: (1) producing, or productive, departments, and (2) nonproducing, or service, departments. A producing department is one in which manual and machine operations are performed directly upon any part of the product manufactured. A service department is one that is not directly engaged in production but renders a particular type of service for the benefit of other departments. The expense incurred in the operation of service departments represents a part of the total factory overhead that must be absorbed in the cost of the product.

For **product costing**, the factory may be divided into departments, and departments may also be subdivided into cost centers. As a product passes through a cost center or department, it is charged with a share of the indirect expenses on the basis of a departmental factory-overhead rate. For cost-control purposes, budgets are established for departments and cost centers. Actual expenses are compared with budget allowances in order to determine the efficiency of a department and to measure the manager's success in controlling expenses.

Factory overhead, which is charged to a product or a job on the basis

**Balance Sheet (Illustrative)**  
**Black Carbon, Inc.**

December 31, 19–

Assets		
<b>Current Assets:</b>		
Cash .....	\$ 5,050,000	
Accounts Receivable (net) .....	6,990,000	
<b>Inventories:</b>		
Raw Materials and Supplies .....	\$ 1,000,000	
Work in Process .....	1,800,000	
Finished Goods .....	2,900,000	5,700,000
Investments .....	1,000,000	
Deferred Charges .....	340,000	
<b>Total Current Assets .....</b>		<b>\$19,080,000</b>
<b>Property, Plant, and Equipment:</b>		
Land .....	\$ 4,000,000	
Buildings and Equipment .....	\$75,500,000	
Less: Allowance for Depreciation .....	47,300,000	28,200,000
<b>Total Fixed Assets .....</b>		<b>32,200,000</b>
<b>Total Assets .....</b>		<b><u>\$51,280,000</u></b>
Liabilities		
<b>Current Liabilities:</b>		
Accounts Payable and Accruals .....	\$ 3,580,000	
<b>Provision for Income Taxes:</b>		
Federal .....	\$ 2,250,000	
State .....	65,000	2,315,000
<b>Total Current Liabilities .....</b>		<b>\$ 5,895,000</b>
Long-term Debt .....		5,300,000
<b>Total Liabilities .....</b>		<b><u>\$11,195,000</u></b>
<b>Stockholders Equity:</b>		
Common Stock—no par value		
Authorized—2,000,000 shares		
Outstanding—1,190,000 shares .....	\$11,900,000	
Earnings retained in the business .....	28,185,000	
<b>Total Stockholders' Equity .....</b>		<b>\$40,085,000</b>
<b>Total Liabilities and Stockholders' Equity .....</b>		<b><u>\$51,280,000</u></b>

**Income Statement (Illustrative)**  
**Black Carbon, Inc.**

for the year 19–

Net Sales .....		\$50,087,000
<b>Cost of products:</b>		
Material, Labor, and Overhead (excluding depreciation) .....	\$32,150,000	
Depreciation .....	5,420,000	37,570,000
Gross Profit .....		<u>\$12,517,000</u>
Less: Selling and Administrative Expenses .....		3,220,000
Profit from Operations .....		<u>9,297,000</u>
Other Deductions .....		305,000
		<u>8,992,000</u>
Other Income .....		219,000
Income before Federal and State Income Taxes .....		<u>9,211,000</u>
Less: Provision for Federal and State Income Taxes .....		4,055,000
Total Net Income .....		<u>5,156,000</u>
Dividends paid to shareholders .....		2,200,000
Income retained in the business .....		<u>\$ 2,956,000</u>

**Statement of Cash Flows (Illustrative)**  
**Black Carbon, Inc.**

December 31, 19–

<b>Cash flows from operating activities</b>		
Cash received from customers .....	\$49,525,000	
Cash paid to suppliers and employees .....	(40,890,000)	
Cash paid for interest .....	(1,050,000)	
Cash paid for income taxes .....	(2,860,000)	
Net cash provided by operating activities .....		\$ 4,725,000
<b>Cash flows from investing activities</b>		
Purchase of equipment .....	(1,970,000)	
Net cash from investing activities .....		(1,970,000)
<b>Cash flows from financing activities</b>		
Principal payment on loans .....	(2,780,000)	
Dividend payments .....	(2,200,000)	
Net cash used by financing activities .....		(4,980,000)
Net increase (decrease) in cash .....		(2,225,000)
Cash at beginning of year .....		7,275,000
Cash at end of year .....		\$ 5,050,000

**Fig. 17.2.1** Examples of the balance sheet, income statement, and statement of cash flows based on the published annual report.

## 17-14 COST ACCOUNTING

of a predetermined overhead rate, is considered indirect with regard to the product or the job to which the expense is charged. Service-department expenses are prorated to other service departments and/or to the producing departments. The proration is accomplished by using some rational basis such as area occupied or number of workers. The prorated costs are termed **indirect departmental charges**. When all service-department expenses have been prorated to the producing departments, each producing department's total factory overhead will consist of its own direct departmental expense and the indirect (or prorated, or apportioned) charges. This total cost is charged to the product or the job on the basis of the predetermined factory-overhead rate.

A company's cost system provides the data required for establishing **standard costs** and for the preparation and operation of a **budget**.

The **budget** program enlists all members of management in the task of creating a workable and acceptable plan of action, welds the plan into a homogeneous unit, communicates to the managerial levels differences between planned activity and actual performance, and points out unfavorable conditions which need corrective action. The budget not only will help promote coordination of people, clarification of policy, and crystallization of plans, but with successful use will create greater internal harmony and unanimity of purpose among managers and workers.

The established **standard-cost** values for material, labor, and factory overhead form the foundation for the budget. Since standard costs are an invaluable aid in the process of setting prices, it is essential to set these standard costs at realistic levels. The measurement of deviations from established standards or norms is accomplished through the use of variance accounts.

Costs as a basis for planning are estimated costs which may be incurred if any one of several alternative courses of action is adopted. Different types of costs involve varying kinds of consideration in managerial planning and decision making.

### METHODS OF ACCUMULATING COSTS IN RECORDS OF ACCOUNT

The balance sheet lists the components of inventory as raw materials, work in process, and finished goods. These accounts reflect the cost of unsold production at various stages of completion. The costs in work in process and finished goods are accumulated or tabulated in the record of accounts according to one of two methods:

**1. The Job-Order Cost Method** When orders are placed in the factory for specific jobs or lots of product, which can be identified through all manufacturing processes, a job cost system is appropriate. This method has certain characteristics. A manufacturing order often corresponds to a customer's order, though sometimes a manufacturing order may be for stock. The customer's order may be obtained on the basis of a bid price computed from an estimated cost for the job. The goods in each order are kept physically separate from those of other jobs. The costs of a manufacturing order are entered on a job cost sheet which shows the total cost of the job upon completion of the order. This cost is compared with the estimated cost and with the price which the customer agreed to pay.

**2. The Process Cost Method** When production proceeds in a continuous flow, when units of product are not separately identifiable, and when there are no specific jobs or lots of product, a process cost system is appropriate, for it has certain characteristics: work is ordered through the plant for a specific time period until the raw materials on hand have all been processed or until a specified quantity has been produced; goods are sold from the stock of finished goods on hand since a customer's order is not separately processed in the factory; the cost-of-production sheet is a record of the costs incurred in operating the process—or a series of processes—for a period of time. It shows the quantity produced in pounds, tons, gallons, or other units, and the cost per unit is obtained by dividing the total costs of the period by the total units produced. Performance is indicated by comparing the quantity produced and the cost per unit of the current period with similar figures of other periods or with standard cost figures.

### ELEMENTS OF COSTS

The main items of costs shown on the income statement are factory costs which include direct materials, direct labor and factory overhead; and selling and administrative expenses. A breakdown of costs is shown in Figure 17.2.2.

**Materials** The cost of materials purchased is recorded from purchase invoices. When the materials are used in the factory, an assumption must be made as to **cost flow**, that is, whether to charge them to operations at average prices, at costs based on the first-in, first-out method of costing, or at costs based on the last-in, first-out method of costing. Each method will lead to a different cost figure, depending on how prices change. Each situation must be studied individually to determine which practice will give a maximum of accuracy in cost figures with a minimum of accounting and clerical effort. Once the choice has been made, records must be set up to charge materials to operations based on requisitions. Indirect material is necessary to the completion of the product, but its consumption with regard to the final product is either so small or so complex that it would be futile to treat it as a direct-material item.

**Labor** Labor also consists of two categories: direct and indirect. Direct labor, also called **productive labor**, is expended immediately on the materials comprising the finished product. Indirect labor, in contrast to direct labor, cannot be traced specifically to the construction or composition of the finished product. The term includes the labor of supervisors, shop clerks, general helpers, cleaners, and those employees engaged in maintenance work.

**Factory Overhead** Indirect materials or factory supplies and indirect labor constitute an important segment of factory overhead. In addition, costs of fuel, power, small tools, depreciation, taxes on real estate, patent amortization, rent, inspection, supervision, social security taxes, health and accident insurance, workers' compensation insurance, and many others fall into this large category. These expenses must be collected and allocated to all jobs or units produced. Many expenses are definitely applicable to a specific department and are easily assigned thereto. Other expenses relate to the entire plant and must be prorated to departments on some suitable basis. For instance, heat might be prorated to departments on the basis of volume of space occupied. The expenses of the service departments are prorated to the producing departments on some basis such as service rendered in the case of a maintenance department or so much dollar payroll processed in the case of a cost department.

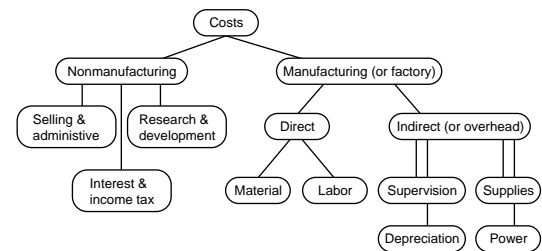

Fig. 17.2.2 Summary diagram of cost relationships.

The charging of factory overhead to jobs or products is accomplished by means of an overhead or burden rate. This rate is essentially a ratio computed to show the relationship of the total burden of a department to some other easily measurable total figure for the department. For example, the total burden cost of a department may be divided by its direct-labor cost to give a percentage-of-direct-labor rate. This percentage applied to the direct-labor cost of a job or a product gives the amount of overhead chargeable thereto. Other common types of burden rates are the labor-hour rate (departmental expenses ÷ total direct-labor hours) and the machine-hour rate (departmental expenses ÷ total machine hours available). Labor rates are most commonly used. When, however, machines perform the greater amount of the work, machine-hour rates

give better results. It must be clearly understood that these rates are computed in advance of production, generally at the beginning of the year. They are used throughout the fiscal period unless seasonal fluctuations or unusual changes in expense amounts necessitate the creation of a new rate. The determination of the overhead rate is closely tied up with overhead budgets.

### ACTIVITY-BASED COSTING

The method of assigning overhead to products based on labor hours or machine hours is referred to as **volume-based** overhead absorption because the amount assigned will vary strictly with the volume of either labor or machine time consumed. In applications where production costs may not be strictly driven by volume of labor hours, **activity-based** or **transaction** costing is appropriate. This situation typically occurs when there are many options or alternatives available to the customer. Typically, these products are produced in low volumes and have a high degree of complexity. An example would be the option of a premium radio in an automobile. Though the actual purchase cost of that radio would not be overlooked in pricing the automobile, the indirect costs would be overlooked in a volume-based system because the indirect costs associated with the premium radio, such as holding an additional item of inventory, documenting and producing separate receiving orders, added clerical and assembly coordination effort, increased engineering complexity, and so on would be grouped under the general category of overhead. On the other hand, in an activity-based system, indirect costs would be assigned to a unique cost pool, such as shown in Fig. 17.2.3 and 17.2.4, which compare the procedures of volume and

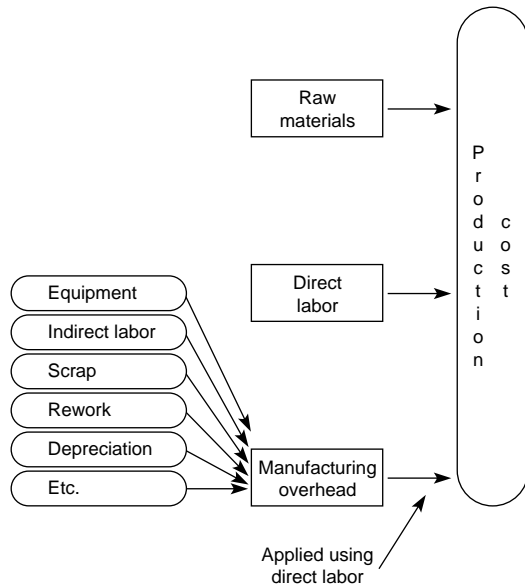

Fig. 17.2.3 Volume-based costing.

activity-based costing. The striking difference is that the overhead cost pool used in volume systems is not present. In activity-based systems, many more cost pools are used and are closely related to some **causal aspect** of the process such as machine setup, receiving orders, or material movement. The costs are assigned to products based on the relative amounts of each cost driver consumed by that product. Therefore, low-volume options such as the premium radio receive a larger share of indirect costs relative to the actual volume of labor used to insert the component. The amount of each cost pool attributed to a product can then be spread over the number of units produced and a more accurate assignment of costs obtained.

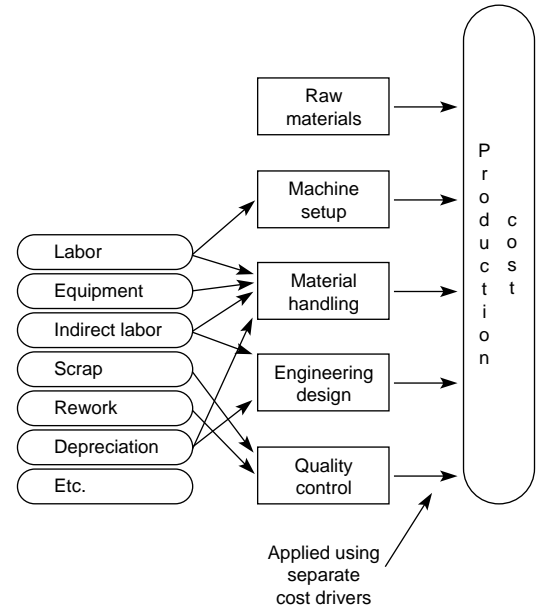

Fig. 17.2.4 Activity-based costing.

**Departmental Classification** As mentioned above, the establishment of departmental lines is important not only for costing purposes but also for budgetary control purposes. Departmental lines are set up in order to (1) segregate basically different processes of production, (2) secure the smoothest possible flow of production, and (3) establish lines of responsibility for control over production and costs. When the costing methods are designed to fit in with the departmentalization of factory and office, costs can be accumulated within a department with production being on either the job-order or process cost method.

### MANAGEMENT AND THE CONTROL FUNCTION

To be successful, management must integrate its own knowledge, skills, and practices with the know-how and experience of those who are entrusted with the task of carrying out company objectives. Management, together with its employees and workers, can achieve its objectives through performance of the three managerial functions: (1) planning and setting objectives, (2) organizing, and (3) controlling.

**Planning** is a basic function of the management process. Without planning there is no need to organize or control. However, planning must precede doing, and the budget is the most important planning tool of an enterprise.

**Organizing** is essentially the establishment of the framework within which the required activities are to be performed, together with a list of who should perform them. Creation of an organization requires the establishment of organizational or functional units generally known as departments, divisions, sections, floors, branches, etc.

**Controlling** is the process or procedure by which management ensures operative performance which corresponds with plans. The control process is pictured diagrammatically in Fig. 17.2.5. Recognition of accounting as an important tool in the controlling phase is evidenced through the role of performance reports in pointing out areas and jobs or tasks which require corrective action. These reports should make possible "management by exception."

The effectiveness of the control of costs depends upon proper communication through control and action reports from the accountant to the various levels of operating management. An organization chart is essential to the development of a cost system and cost reports which parallel the responsibilities of individuals for implementing manage-

## 17-16 COST ACCOUNTING

ment plans. The coordinated development of a company's organization with the cost and budgetary system will lead to "responsibility accounting." Responsibility accounting plays a key role in determining the type of cost system used.

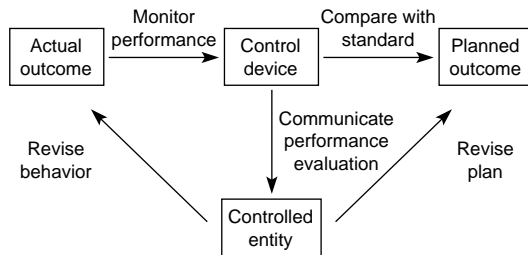

Fig. 17.2.5 The control process.

### TYPES OF COST SYSTEMS

The construction of a cost system requires a thorough understanding of (1) the organizational structure of the company, (2) the manufacturing procedure, and (3) the type of information which management requires of the cost system.

1. The organization chart gives a graphic picture of the ranking authority of superintendents, department heads, and managers who are responsible for (a) providing the detailed information needed by the accounting division in order to install a successful system; (b) incurring expenditures in personnel, materials, and other cost elements, which the cost accountant must segregate and report to those in charge. The cost system with its operating accounts must correspond to organizational divisions of authority so that the individual supervisor, department head, or executive can be held "accountable" for the costs incurred in the department.

2. The manufacturing procedure and shop methods lead to a consideration of the type of pay (piece rate, incentive, day rate, etc.); the method of collecting hours worked; the control of inventories; the problem of costing tools, dies, jigs, and machinery; and many other problems connected with the factory.

3. The organizational setup on the one hand and the manufacturing procedure on the other form the background for the design of a cost system that is based on (a) recognition of the various cost elements, (b) departmentalization of factory and office, and (c) the chart of accounts.

Any cost system should be perfected so that it will (1) aid in the control and management of the company; (2) measure the efficiency of personnel, materials, and machines; (3) help in eliminating waste; (4) provide comparison within individual industries; (5) provide a means of valuing inventories; and (6) aid in establishing selling prices. In an organization departmentalized or segmented along product lines, it is often arbitrary to allocate certain indirect costs especially when common facilities or personnel are shared. This is because there is no objective basis to compute a division of common costs. Control methods for evaluating performance often rely on the **segment margin** statement.

#### Example of a Segment Margin Statement

	Product A	Product B	Total
Sales	\$9,000	\$11,000	\$20,000
Direct material & labor	(4,000)	(5,000)	(9,000)
Contribution margin	5,000	6,000	11,000
Product specific overhead	(1,000)	(2,500)	(3,500)
Segment margin	4,000	3,500	7,500
Common costs			(2,000)
Operating income			\$ 5,500

The cost system's value is greatly enhanced when it is interlocked with a **budgetary control system**. When budget figures are based upon standard costs, the greatest benefit will be derived from such a combination.

Basically, two types of cost systems exist: (1) the **actual** (or **historical**) and (2) the **standard** (or **predetermined**). The actual cost system accumulates and summarizes costs as they occur and determines a final product cost after all manufacturing operations have been completed. The job is charged with actual quantities and costs of materials used and labor expended; the overhead or burden is allocated on the basis of some predetermined overhead rate. This predetermined overhead rate shows that even the so-called **actual system** does not entirely live up to its name. Under a standard cost system all costs are predetermined in advance of production. Both the actual (historical) and the standard cost system may be used in connection with either (1) the job-order cost method or (2) the process cost method.

### BUDGETS AND STANDARD COSTS

A budget provides management with the information necessary to attain the following major objectives of budgetary control: (1) an organized procedure for planning; (2) a means for coordinating the activities of the various divisions of a business; (3) a basis for cost control. The planning phase provides the means for formalizing and coordinating the plans of the many individuals whose decisions influence the conduct of a business. Sales, production, and expense budgets must be established. Their establishment leads necessarily to the second phase of coordination. Production must be planned in relation to expected sales, materials and labor must be acquired or hired in line with expected production requirements, facilities must be expanded only as foreseeable future needs justify, and finances must be planned in relation to volume of sales and production. The third phase of cost control is predicated on the idea that actual costs will be compared with budgeted costs, thus relating what actually happened with what should have happened. To accomplish this purpose, a good measure of what costs should be under any given set of conditions must be provided. The most important condition affecting costs is volume or rate of activity. By predetermining, through the use of the flexible budget, the expenses allowed for any given rate of activity and comparing it with the actual expense, a better measurement of the performance of an individual department is achieved and the control of costs is more readily accomplished.

In the construction of overhead budgets the volume or activity of the entire organization as well as of the individual department is of considerable importance in their relationship to existing capacity. Capacity must be looked upon as that fixed amount of plant, machinery, and personnel to which management has committed itself and with which it expects to conduct the business. Volume or activity is the variable factor in business related to capacity by the fact that volume attempts to make the best use of the existing capacity. To find a profitable solution to this relationship is one of the most difficult problems faced by business management and the accountant who tries to help with appropriate cost data. Volume, particularly of a department, is often expressed in terms of direct-labor hours. With different rates of capacity, a different cost per hour of labor will be computed. This relationship can be demonstrated in the following manner:

Percentage of productive capacity	60%	80%	100%
Direct-labor hours	600	800	1,000
Factory overhead			
Fixed overhead	\$1,200	\$1,200	\$1,200
Variable overhead	600	800	1,000
Total	\$1,800	\$2,000	\$2,200
Overhead rate per direct-labor hour	\$3.00	\$2.50	\$2.20

The existence of fixed overhead causes a higher rate at lower capacity. It is desirable to select that overhead rate which permits a full recovery of production costs by the end of the business cycle. The above tabulation reveals another important axiom with respect to fixed and variable overhead. Fixed overhead remains constant in total but varies in respect to cost per unit or hour. Variable overhead varies in total but remains fixed in relationship to the unit or hour.



**Standard Costs** The budget, as a statement of expected costs, acts as a guidepost which keeps business on a charted course. Standards, however, do not tell what the costs are expected to be but rather what they will be if certain performances are attained. In a well-managed business, costs never exceed the budget. They should constantly approach predetermined standards. The uses of standard costs are of prime importance for (1) controlling and reducing costs, (2) promoting and measuring efficiencies, (3) simplifying the costing procedures, (4) evaluating inventories, (5) calculating and setting selling prices. The success of a standard cost system depends upon the reliability and accuracy of the standards. To be effective, standards should be established for a definite period of time so that control can be exercised and variances from standards computed. Standards are set for materials, labor, and factory overhead. When actual costs differ from standard costs with respect to material and labor, two causes can generally be detected. (1) The price may be higher or lower or the rate paid a worker may be different; the difference is called a material price or a labor rate variance. (2) The quantity of the material used may be more or less than the standard quantity or the hours used by the worker may be more or less. The difference is called material-quantity variance or labor-efficiency variance, respectively. For factory overhead, the computation is somewhat more elaborate. Actual expenses are compared not only with standard expenses but also with budget figures. Various methods are in vogue, resulting in different kinds of overhead variances. Most accountants compute a controllable and a volume variance. The controllable variance deals chiefly with variable expenses and measures the efficiency of the manager's ability to hold costs within the budget allowance. The volume variance portrays fixed overhead with respect to the use or nonuse of existing capacity. It measures the success of management in its ability to fill capacity with sales or production volume. These two variances can be analyzed further into an expenditure and efficiency variance for the controllable variances and into an effectiveness and capacity variance for the volume variance. Such detailed analyses might bring forth additional information which would help management in making decisions. Of absolute importance for any cost system is the fact that the information must reach management promptly, with regularity, and in a report that is analytical, permitting quick comparison with targets and goals. Only in this manner can management, which includes all echelons from the foreman to the president, exercise control over costs and therewith over profits.

#### TRANSFER PRICING

A **transfer price** refers to the selling price of a good or service when both the buyer and seller are within the same organization. For example, one division of a company may produce a component, such as an engine, and transfer this component to an assembly division. For purposes of control, these organizational units may be treated as **profit centers** (responsible for earning a specified profit or return on investment). Accordingly, the transfer price is a revenue for the seller and a cost to the buyer. Because organizational control is at issue whenever interdivisional transfers are made, companies must often specify a policy to dictate the basis for determining a transfer price. Transfer prices should be based on market prices when available. Most taxing authorities require intercompany transfers to be made at market price as well. To solve situations of suboptimal resource usage (e.g., idle capacity) it is often possible to construct transfer prices based on manufacturing cost plus some allowance for profit. If the producing division is a **cost center** (responsible for controlling costs to achieve a certain budgeted level), in order to promote efficiency transfers are usually made on the basis of **standard cost**.

#### SUPPORTING DECISION MAKING

The analytical phase of cost accounting has become more important and influential in the last few years. Management must make many decisions, some of a short-range, others of a long-range nature. To base judgment upon good, reliable data and analyses is a major task for

controllers and their staffs. Cost analysis comprises such matters as analysis of distribution costs, gross-profit analysis, break-even analysis, profit-volume analysis, differential-cost analysis, direct costing, capital-expenditure analysis, return on capital employed, and price analysis. A detailed discussion of each phase mentioned lies beyond the scope of this section, but a short description is appropriate.

**Distribution-cost** analysis deals with allocation of selling expenses to territories, customers, channels of distribution, products, and sales representatives. Once so allocated it might be possible to determine the most profitable and the least profitable commodity, product, territory, or customer. Segment margin statements are useful for this analysis. Standards have been introduced recently in these analyses. The Robinson-Patman Act, an amendment to Section 2 of the Clayton Act, gave additional impetus to the analytical phase of distribution costs. This act prohibits pricing the same product at different amounts when the amounts do not reflect actual cost differences (such as distribution or warranty).

**Gross-profit** analysis attempts to determine the causes for an increase or decrease in the gross profit. Any change in the gross profit is due to one or a combination of the following: (1) changes in the selling price of the products; (2) changes in the volume sold; (3) changes in the types of products sold, called the sales-mix; (4) changes in the cost elements. Cost elements are analyzed through budgetary control methods. Sales figures must be scrutinized to unearth the changes from the contemplated course and therewith from the final profit.

**Break-even** analysis, generally presented in the form of a break-even chart, constitutes one of the briefest and most easily understood devices for data presentation for policy-making decisions. The name "break-even" implies that point at which the company neither makes a profit nor suffers a loss from the operations of the business. A break-even chart can be defined as a portrayal in graphic form of the relation of production and sales to profit or, more briefly, a graphic variable income statement. The computation of the break-even point can be made by the following formula.

$$\text{Break-even sales volume} = \frac{\text{total fixed expenses}}{1 - \frac{\text{total variable expenses}}{\text{total sales volume}}}$$

EXAMPLE. Assume fixed expenses, \$13,800,000; variable expenses, \$27,000,000; total sales volume, \$50,000,000. Computation: Break-even sales volume = \$13,800,000/[1 - (\$27,000,000/\$50,000,000)] = \$30,000,000.

Results can be obtained in chart form (Fig. 17.2.6).

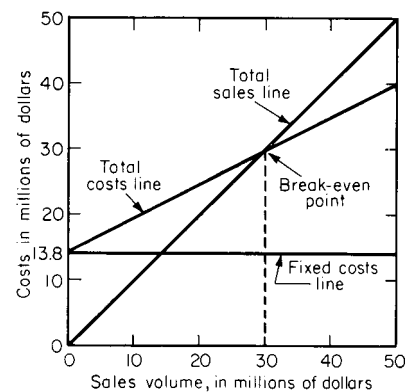

Fig. 17.2.6 Illustrative break-even chart.

**Cost-volume-profit** analysis deals with the effect that a change of volume, cost, price, and product-mix will have on profits. Managements of many enterprises attempt to stimulate the public to purchase their products by conducting intensive promotion campaigns in radio, press, mail, and television. The customer, however, makes the final decision. What

## 17-18 COST ACCOUNTING

management wants to know is which product or model will yield the most profitable margin; which is the least profitable; what effect a reduction in sales price will have on final profit; what effect a shift in volume or product-mix will have on product costs and profits; what the new break-even point will be under such changing conditions; what the effect of expected increases in wages or other operating costs on profit will be; what the effect will be on costs, profit, and sales volume should there be an expansion of the plant. Cost-volume-profit analysis can also be presented graphically in a so-called *volume-profit-analysis graph*. Using the same data as in the break-even chart, a volume-profit analysis graph takes the form shown in Fig. 17.2.7.

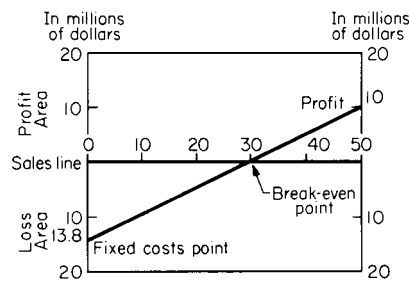

Fig. 17.2.7 Illustrative cost-volume-profit analysis graph.

**Differential-cost** analysis treats differences, as the title suggests. These differences, also called alternative courses, arise when management wants to know whether or not to take business at a special price, to risk a decline in price of total sales, to sacrifice volume for price, to shut down part of the plant, or to enlarge plant capacity. While accountants generally use the term “**differential**,” economists speak of “**marginal**” and engineers of “**incremental**” costs in connection with such a study. As in any of the previously discussed analyses, the classification of costs into their fixed and variable components is absolutely essential. However, while in break-even analysis the emphasis rests upon the fixed expenses, differential-cost studies stress the variable costs. The differential-cost statement presents only the differences in the following manner:

	Present business	Additional business	Total
Sales	\$100,000	\$10,000	\$110,000
Variable costs	60,000	6,000	66,000
Marginal income	40,000	4,000	44,000
Fixed expenses	30,000	none	30,000
Profit	\$ 10,000	\$ 4,000	\$ 14,000

This statement shows that additional business is charged with the variable expenses only because present business is absorbing all fixed expenses.

**Direct costing** is a costing method which charges the products with only those costs that vary directly with volume. Variable or direct costs such as direct materials, direct labor, and variable manufacturing expenses are examples of costs chargeable to the product. Costs that are a function of time rather than of production are excluded from the cost of the product. The only costs assignable to inventories are variable costs, and because they should vary in proportion to increases or decreases in production, the unit cost assigned to inventories should be uniform.

### CAPITAL-EXPENDITURE DECISIONS

The preparation of a capital-expenditure budget must be preceded by an analytical and decision-making process by management. This area of managerial decisions not only is important to the success of the company but also is crucial in case of errors. Financial requirements, present

and anticipated costs, profits, tax considerations, and legal, personnel, and market problems must be studied and reviewed before making the final decision.

Four evaluation techniques are generally accepted as representative tools for decision making: (1) **payback- or payout-period method**; (2) **average-return-on-investment method**; (3) **present-value method**; and (4) **discounted-cash-flow method**. None of these methods serves every purpose or every firm. The methods should, however, aid management in exercising judgment and making decisions. Of significance in the evaluation of a capital expenditure is the time value of money which is employed in the present value and the discounted-cash-flow methods. The **present value** means that a dollar received a year hence is not the equivalent of a dollar received today, because the use of money has a value. For this reason, the estimated results of an investment proposal can be stated as a cash equivalent at the present time, i.e., its present value. Present-value tables have been devised to facilitate application of present-value theory.

In the present-value method the discount rate is known or at least predetermined. In the **discounted-cash-flow (DCF)** method the rate is to be calculated and is defined as the rate of discount at which the sum of positive present values equals the sum of negative present values. The DCF method permits management to amortize corporate profits by selecting proposals with the highest rates of return as long as the rates are higher than the company’s own **cost of capital** plus management’s allowance for risk and uncertainty. Cost of capital represents the expected return for a given level of risk that investors demand for investing their money in a given firm or venture. However, when related to capital-expenditure planning, the cost of capital refers to a specific cost of capital from a particular financing effort to provide funds for a specific project or numerous projects. Such use of the concept connotes the marginal cost of capital point of view and implies linkage of the financing and investment decisions. It is, therefore, not surprising that the cost of capital differs, depending upon the sources. A company could obtain funds from (1) bonds, (2) preferred and common stock, (3) use of retained earnings, and (4) loans from banks. If a company obtains funds by some combination of these sources to achieve or maintain a particular capital structure, then the cost of capital (money) is the weighted average cost of each money source.

**Return-on-Capital Concept** This aids management in making decisions with respect to proposed capital expenditures. This concept can also be used for (1) measuring operating performance, (2) profit planning and decision making, and (3) product pricing. The return on capital may be expressed as the product of two factors: the percentage of profit to sales and the rate of capital turnover. In the form of an equation, the method appears as

$$\frac{\text{Profit}}{\text{Sales}} = \text{profit margin} \quad \downarrow$$

$$\times \rightarrow = \text{return on capital investment}$$

$$\frac{\text{Sales}}{\text{Capital}} = \text{investment turnover} \quad \uparrow$$

Whether for top executive, plant or product manager, plant engineer, sales representative, or accountant, the concept of return on capital employed tends to mesh the interest of the entire organization. An understanding and appreciation of the return-on-capital concept by all employees help in building an organization interested in achieving fair profits and an adequate rate of return.

### COST MANAGEMENT

Often, programs of **continuous improvement** require that costs be computed according to the activity-based method. That method facilitates identifying and setting priorities for the elimination of non-value-adding activities. **Non-value-added** activities decrease cycle time efficiency, where cycle time efficiency is the sum of all value-added activity times

divided by total cycle time. The engineer may redesign the product using common parts or through process redesign so as to eliminate those activities or cost pools that add to product cost without adding to value. Some examples of these activities are material movement, run setup, and queue time.

Efforts to manage product costs by eliminating non-value-adding activities are frequently the result of a need to attain a specific target cost. Traditionally selling price was determined by adding a required markup

to total cost. Global competition has forced producers to accept a market price determined by competitive forces:

$$\text{Target cost} = \text{market selling price} - \text{required return on investment}$$

Accordingly, the company that stays in business is the one that can accept this price and still earn a return on investment. **Target costing** is a concerted effort to design, produce, and deliver the product at a cost that will assure long-term survival.

## 17.3 ENGINEERING STATISTICS AND QUALITY CONTROL

Ashley C. Cockerill

REFERENCES: Brownlee, "Statistical Theory and Methodology in Science and Engineering," Wiley. Conover, Two  $k$ -sample slippage tests, *Journal of the American Statistical Association*, **63**: 614–626. Conover, "Practical Nonparametric Statistics," Wiley. Duncan, "Quality Control and Industrial Statistics," Richard D. Irwin. Gibbons, "Nonparametric Statistical Inference," McGraw-Hill. Olmstead, A corner test for association, *Annals of Mathematical Statistics*, **18**: 495–513. Owen, "Handbook of Statistical Tables," Addison-Wesley. Pearson, "Biometrika Tables for Statisticians," vol. 1, 2d ed., Cambridge University Press. Tukey, "A quick compact two sample test to Duckworth's specifications," *Technometrics*, **1**: 31–48. Wilks, "Mathematical Statistics," Wiley.

### ENGINEERING STATISTICS AND QUALITY CONTROL

Statistical models and statistical methods play an important role in modern engineering. Phenomena such as turbulence, vibration, and the strength of fiber bundles have statistical models for some of their underlying theories. Engineers now have available to them batteries of computer programs to assist in the analysis of masses of complex data. Many textbooks are needed to cover fully all these models and methods; many are areas of specialization in themselves. On the other hand, every engineer has a need for easy-to-use, self-contained statistical methods to assist in the analysis of data and the planning of tests and experiments. The sections to follow give methods that can be used in many everyday situations, yet they require a minimum of background to use and need little, if any, calculation to obtain good results.

### STATISTICS AND VARIABILITY

One of the primary problems in the interpretation of engineering and scientific data is coping with **variability**. Variability is inherent in every physical process; no two individuals in any population are the same. For example, it makes no real sense to speak of the tensile strength of a synthetic fiber manufactured under certain conditions; some of the fibers will be stronger than others. Many factors, including variations of raw materials, operation of equipment, and test conditions themselves, may account for differences. Some factors may be carefully controlled, but variability will be observed in any data taken from the process. Even tightly designed and controlled laboratory experiments will exhibit variability.

Variability or variation is one of the basic concepts of statistics. Statistical methods are aimed at giving objective, quantitative, and reproducible ways of assessing the effects of variability. In particular, they aim to provide measures of the uncertainty in conclusions drawn from observational data that are inherently variable.

A second important concept is that of a **random sample**. To make valid inferences or conclusions from a set of observational data, the data should be able to be considered a random sample. What does this mean? In an operational sense it means that everything we are interested in seeing should have an equal chance of being represented in the observa-

tions we obtain. Some examples of what not to do may help. If machine setup is an important contributor to differences, then all observations should not be taken from one setup. If instrumental variation can be important, then measurements on the same item should not be taken successively—time to "forget" the last reading should pass. A random sample of  $n$  items in a warehouse is not the first  $n$  that you can find. It is the  $n$  that is selected by a procedure guaranteed to give each item of interest an equal chance of selection. One should be guided by generalizations of the fact that the apples on top of a basket may not be representative of all apples in the basket.

### CHARACTERIZING OBSERVATIONAL DATA: THE AVERAGE AND STANDARD DEVIATION

The two statistics most commonly used to characterize observational data are the **average** and the **standard deviation**. Denote by  $x_1, x_2, \dots, x_n$  the  $n$  individual observations in a random sample from some process. Then the average and standard deviation are defined as follows:

Average:

$$\bar{x} = \sum_{i=1}^n x_i/n$$

Standard deviation:

$$s = \left[ \sum_{i=1}^n (x_i - \bar{x})^2 / (n - 1) \right]^{1/2}$$

Clearly, the average gives one number around which the  $n$  observations tend to cluster. The standard deviation gives a measure of how the  $n$  observations vary or spread about this average. The square of the standard deviation is called the **variance**. If we consider a unit mass at each point  $x_i$ , then the variance is equivalent to a moment of inertia about an axis through  $\bar{x}$ . It is readily seen that for a fixed value of  $\bar{x}$ , greater spreads from the average will produce larger values of the standard deviation  $s$ . The average and the standard deviation can be used jointly to summarize where the observations are concentrated. Chebyshev's theorem states: A fraction of at least  $1 - (1/k^2)$  of the observations lie within  $k$  standard deviations of the average. The theorem guarantees lower bounds on the percentage of observations within  $k$  (also known as  $z$  in some textbooks) standard deviations of the average.

Interval	Lower bound on % of measurements
$\bar{x} - 2s$ to $\bar{x} + 2s$	75%
$\bar{x} - 3s$ to $\bar{x} + 3s$	89%
$\bar{x} - 4s$ to $\bar{x} + 4s$	94%
$\bar{x} - 5s$ to $\bar{x} + 5s$	96%
$\bar{x} - 6s$ to $\bar{x} + 6s$	97%

17-20 ENGINEERING STATISTICS AND QUALITY CONTROL

Table 17.3.1 Average of Range  $f_n = \sigma$

Sample size	$f_n$	Sample size	$f_n$
2	0.8862	11	0.3152
3	0.5908	12	0.3069
4	0.4857	13	0.2998
5	0.4299	14	0.2935
6	0.3946	15	0.2880
7	0.3698	16	0.2831
8	0.3512	17	0.2787
9	0.3367	18	0.2747
10	0.3249	19	0.2711
		20	0.2677

Since the average and the standard deviation are computed from a sample, they are themselves subject to fluctuation. However, if  $\mu$  is the long-term average of the process and  $\sigma$  is the long-term standard deviation, then:

Average ( $\bar{x}$ ) =  $\mu$ , process average  
 Average ( $s$ ) =  $\sigma$ , process standard deviation

Furthermore, the intervals  $\mu \pm k\sigma$  contain the same percentage of all values, as do the intervals  $\bar{x} \pm ks$  for the sample; that is, at least 89 percent of all the long-term values will be contained in the interval  $\mu - 3\sigma$  to  $\mu + 3\sigma$ , etc.

Range Estimate of the Standard Deviation

For  $n \leq 20$  it is more convenient to compute the range  $r$  to estimate the standard deviation  $\sigma$ . The range is  $x_{(n)} - x_{(1)}$ , where  $x_{(n)}$  is the largest value in a random sample of size  $n$  and  $x_{(1)}$  is the smallest value. For example, if  $n = 10$  and the observations are 310, 309, 312, 316, 314, 303, 306, 308, 302, 305, the range is  $r = 316 - 302 = 14$ . An estimate of the standard deviation  $\sigma$  is obtained by multiplying  $r$  by the factor  $f_n$  in Table 17.3.1. The average value of  $r \cdot f_n$  is  $\sigma$ . Thus, in the example above, an estimate of  $\sigma$  and a value that can be used for  $s$  is  $0.3249r = 0.3249(14) = 4.5486$ .

PROCESS VARIABILITY—HOW MUCH DATA?

Since the output of all processes is variable, one can make reasonable decisions about the output only if one can obtain a measure of how much variability or spread one can expect to see under normal conditions. Variability cannot be measured accurately with a small amount of data. Methods for assessing how much data are needed are given for two general situations.

Specified Tolerances

A convenient statement about the variability or spread of a process can be based on the smallest and largest values in a random sample of the output. There are no practical limitations on its use. Suppose that we have a random sample of  $n$  values from our process. Denote the values by  $X_1, X_2, \dots, X_n$ . After obtaining the values we find the smallest,  $X_{(1)}$ , and the largest,  $X_{(n)}$ . Now we want to assess what percent of all future values that this process might generate will be covered by  $X_{(1)}$  and  $X_{(n)}$ . In statistics,  $X_{(1)}$  and  $X_{(n)}$  are called **tolerance limits**. If the process generates bolts and  $X$  is the diameter, then the engineering concept of tolerance and the statistical concept of tolerance are seen to be quite similar.

Let  $p$  be the percentage of all the process values that on a long-term basis will be between  $X_{(1)}$  and  $X_{(n)}$ . Let  $P$  be a lower bound for this percentage  $p$ . Now consider the probability statement: Probability ( $p \geq P$ ) =  $C$ . The quantity  $C$  we call **confidence**. Since it is a probability its value is between 0 and 1. As  $C$  approaches 1 our confidence in the percentage  $P$  increases. The interpretation of  $P$  and  $C$  can be explained in terms of Table 17.3.2.

Suppose that we take a random sample of size  $n = 269$  values from our process output; the smallest value is 10 and the largest is 54. In Table 17.3.2 we see that 269 is the entry for  $P = 99$  and  $C = 0.75$ . This tells us that at least  $P = 99$  percent of all future values that this process

Table 17.3.2

P, %	Confidence, C			
	0.995	0.99	0.95	0.75
99.9	7427	6636	4742	2692
99.5	1483	1325	947	538
99	740	661	473	269
98	368	330	235	134
97	245	219	156	89
96	183	163	117	67
95	146	130	93	53
90	71	64	46	26
80	34	31	22	13
75	27	24	18	10

NOTE: Sample size  $r$  required to have a confidence  $C$  that at least  $P$  percent of all future values will be included between the smallest and largest values in a random sample.

will generate will be between 10 and 54, the smallest and largest values seen in the sample of 269. The confidence  $C = 0.75 = 3/4$  tells us that the chances are 3 out of 4 that our statement is correct. As we increase the sample size  $n$ , we increase the chances that our statement is correct. For example, if our sample size had been  $n = 473$ , then  $C = 0.95$  and the chances are 95 in 100 that we are correct in making the statement that at least 99 percent of all process values will be between the 10 and 54 seen in the sample. Similarly, if the sample size had been 740, then the chances of being correct increase to 995 in 1000. If sample size  $n$  is decreased sufficiently, the confidence  $C = 0.50 = 1/2$  indicates that the chances are one in two of being right, and one in two of being wrong. Therefore, it is important to select  $n$  so as to keep  $C$  as large as possible. The cost of acquiring the data will determine the upper limit for  $n$ .

Further information on tolerance limits can be found in Wilks (1962) and Duncan (1986).

Wear-Out and Life Tests

A special case of coverage occurs if our interest is in a wear-out phenomenon or a life test. For example, suppose we put a number of incandescent light bulbs on test; our interest is in the length of time to failure. Clearly we do not want to wait until all specimens fail to draw a conclusion; it might take an inordinate length of time for the last one to fail. From a practical point of view we would probably be interested in those that fail first anyway. If the sample size is properly chosen, there will be important information as soon as we obtain the first failure.

In a random sample of size  $n$  let the failure times be  $T_1 \geq T_2 \geq \dots \geq T_n$ . The value  $T_1$  is thus the smallest value in a random sample of size  $n$ . Now let  $q$  be the percentage of future units that can be expected to fail in a time less than  $T_1$ , the smallest value in the sample. As before we can make a probability statement about  $q$ . Let  $Q$  be an upper bound to  $q$ . Then we can compute: Probability ( $q \leq Q$ ) =  $C$ .

For example, suppose that we put a random sample of 299 items on test and the first one fails in time  $T_1 = 151$  h. From Table 17.3.3 we see that 299 is an entry for  $Q = 1$  and  $C = 0.95$ . Thus we can conclude

Table 17.3.3

Q, %	Confidence, C			
	0.995	0.99	0.95	0.75
0.1	5296	4603	2995	1386
1	528	459	299	138
2	263	228	149	69
3	174	152	99	46
4	130	113	74	34
5	104	90	59	28
10	51	44	29	14
15	33	29	19	9
20	24	21	14	7
25	19	17	11	5

NOTE: Sample size  $r$  required to have a confidence  $C$  that fewer than  $Q$  percent of future units will fail in a time shorter than the shortest life in the sample. For a more extensive table of values, see Owen (1962).

that not more than 1 percent of future units should fail in a time less than 151 h. The confidence in the statement is 95 chances in 100 of being correct. Again referring to Table 17.3.3, we see that if  $T_1 = 151$  were based on a sample of 528, then the confidence would be increased to 995 chances in 1000. Most importantly, Table 17.3.3 tells us that we need to test a very large sample if we want to have high confidence that only a small percentage of future units will fail in a time less than the smallest observed. The theory behind Table 17.3.3 can be found in Wilks (1962). For a more extensive table of values see Owen (1962). If  $Q' = Q/100$ , use

$$r = [\log(1 - C)] / [\log(1 - Q')]$$

### CORRELATION AND ASSOCIATION

One of the most common problems in the analysis of engineering data is to determine if a correlation or an association exists between two variables  $X$  and  $Y$ , where the data occur in pairs  $(X_i, Y_i)$ . The "corner test of association" developed by Olmstead and Tukey (1947) is a quick and simple test to assist in making this determination.

#### Corner Test

**Conditions for Use** Each pair  $(X_i, Y_i)$  should have been obtained independently; there are no other practical assumptions for its use. Of course, the user should consider the physical process generating the data when interpreting any correlation or association that is determined to exist.

#### Procedure

1. Make a scatter plot on graph paper of the data pairs  $(X_i, Y_i)$ , with the usual convention that  $X$  is the horizontal scale and  $Y$  the vertical.
2. Determine the median  $X_m$  of the  $X_i$  values. Determine the median  $Y_m$  of the  $Y_i$  values.  
The median splits the data into two parts so that there is an equal number of values above and below the median. Let  $N$  denote the total number of points. If  $N$  is odd, then  $N$  can be written as  $2k + 1$  and the median is the  $(k + 1)$ st value as the values are ordered from the smallest to the largest. If  $N$  is even, then  $N$  can be written as  $2k$ . Then the median is taken to be midway between the  $k$ th and  $(k + 1)$ st values.
3. Draw a vertical line through  $X_m$ .
4. Draw a horizontal line through  $Y_m$ .
5. The lines in (3) and (4) divide the graph into four quadrants. Label the upper right and lower left as plus. Label the upper left and lower right as minus.
6. Begin at the right side of the plot. Count the values, in order of decreasing  $X$ , until forced to cross the horizontal median  $Y_m$ . Give the

count a plus sign if the values are in a plus quadrant, a minus sign if they are in a minus quadrant.

7. Repeat the procedure in (6), moving down from above until you have to cross the vertical median, moving from left to right until you have to cross the horizontal median, and moving up from below until you have to cross the vertical median.

8. Compute the algebraic sum of the four counts obtained in (6) and (7). Denote the sum by  $T$ .

**Test** If  $|T| \geq 11$ , then there is evidence of correlation between  $X$  and  $Y$ ;  $|T|$  is the value of  $T$  ignoring the sign.

**EXAMPLE.** Table 17.3.4 gives 33 pairs of values obtained from samples of a paper product. The  $X$  coordinate is proportional to the reciprocal of light transmitted by the sample. The  $Y$  coordinate is proportional to tensile strength.

1. The 33 pairs of values are plotted in Fig. 17.3.1.
2. The median of  $X$  values is  $X_m = 11.94$ . The median of  $Y$  values is  $Y_m = 6.3$ .
- 3 to 5. The medians are shown in Fig. 17.3.1, and the quadrants are labeled.
- 6 to 7. The counts are as follows:

- Right to left: -2 (points at 19.99 and 17.86 on  $X$ )
- Top to bottom: -4 (points at 16.6, 12.9, 12.5, 11.7 on  $Y$ )
- Left to right: -2 (points at 0.93 and 3.18 on  $X$ )
- Bottom to top: -4 (points at 0.1, 1.6, 2.6, 2.7 on  $Y$ )

8. The algebraic sum of the counts is  $-12$ . Hence  $T = -12$ . And since  $|T| \geq 11$ , one can conclude that there is evidence of correlation or association between the variables  $X$  and  $Y$ .

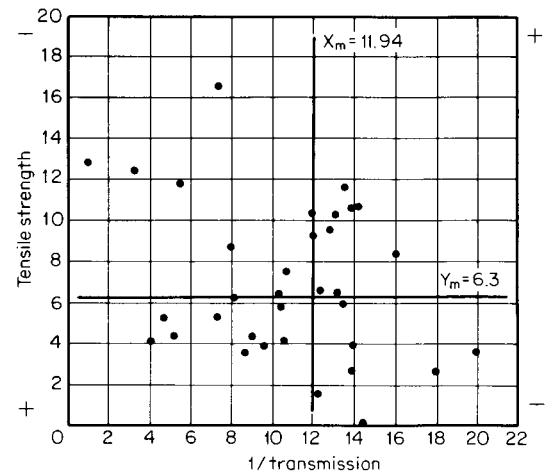

Fig. 17.3.1 Plot of example data used in conjunction with the Corner Test.

Table 17.3.4

$i$	$X$	$Y$	$i$	$X$	$Y$
1	10.45	4.1	18	9.65	3.8
2	13.81	2.7	19	7.44	5.4
3	12.22	1.6	20	10.70	7.6
4	9.05	4.3	21	13.38	6.0
5	17.86	2.6	22	13.00	10.4
6	14.54	0.1	23	13.90	10.7
7	19.99	3.7	24	11.94	9.4
8	8.73	3.5	25	14.11	10.7
9	4.66	5.3	26	0.93	12.9
10	13.88	3.9	27	3.18	12.5
11	5.10	4.4	28	13.13	6.5
12	3.98	4.1	29	13.45	11.7
13	8.12	6.3	30	12.70	9.6
14	12.26	6.6	31	15.95	8.5
15	10.30	6.5	32	7.30	16.6
16	5.40	11.9	33	7.78	8.8
17	10.39	5.8			

NOTE: Data are on paper samples.  $X$  is proportional to reciprocal of light transmission.  $Y$  is proportional to tensile strength.

### COMPARISON OF METHODS OR PROCESSES

A common problem in engineering investigations is that of using experimental or observational data to assess the performance of two processes, two treatment methods, or the like. Often one process or treatment is a standard or the one in current use. The other is an alternative that is a candidate to replace the standard. Sometimes it is cheaper, and one hopes to see no performance difference. Sometimes it is supposed to offer superior performance, and one hopes to see a measurable difference in the variable of interest. In either case we know that the variable of interest will have a distribution of values; and if the two processes are to be measurably different the distribution of values should not overlap too much. For an objective assessment we need to have some way to calibrate the overlap. A quick and easy-to-use test for this purpose is the **outside count test** developed by Tukey (1959).

#### Two Methods—Outside Count Test

**Conditions for Use** Given two groups of measurements taken under conditions 1 and 2 (treatments, methods, etc.), we identify the direction

17-22 ENGINEERING STATISTICS AND QUALITY CONTROL

of difference by insisting that the two groups have minimum overlap. Use 1 to denote the group with the smaller number of measurements and let  $N_1$  be the number of measurements for that group. Let  $N_2$  be the number of measurements for the other group. The number of observations for each group should be about the same.

The conditions to be satisfied are:

$$4 \leq N_1 \leq N_2 \leq 30$$

$$N_2 \leq (4N_1/3) + 3$$

**Procedure**

1. Count the number of values in the one group *exceeding* all values in the other.

2. Count the number of values in the other group *falling below* all those in the other.

3. Sum the two counts in (1) and (2). (It is required that neither count be zero. One group must have the largest value and the other the smallest.)

**Test** If the sum of the two counts in (3) is 7 or larger, there is sufficient evidence to conclude that the two methods are measurably different.

**EXAMPLE.** The following data represent the results of a trial of two methods for increasing the wear resistance of a grinding wheel. The data are proportional to wear:

Method 1: 13.06\*\*, 9.52, 9.98, 8.83, 12.78, 9.00, 11.56, 8.10\*, 12.21.

Method 2: 8.44, 9.64, 9.94, 7.30, 8.74, 6.30\*, 10.78\*\*, 7.24, 9.30, 6.66.

The smallest value for each method is marked with an asterisk; the largest value is marked with two asterisks.

Count 1: The largest value is 13.06 for method 1. The values 13.06, 12.78, 12.21, and 11.56 for method 1 exceed the largest value for method 2, viz., 10.78. Hence the count is 4.

Count 2: The smallest value for method 1 is 8.10. For method 2 the values 7.30, 6.30, 7.24, and 6.66 are less than 8.10. Hence the count is 4.

Count 3: The total count is  $4 + 4 = 8 > 7$ .

The data support the conclusion that method 2 produces measurably less wear than method 1.

**Several Methods**

The problem outlined in the preceding section can be generalized so that one can make a comparison of several processes, treatments, methods, or the like. Again, if there are differences among the methods, the values that we see should not overlap too much. We give you two easy-to-use tests. The first is for the situation where there is an equal amount of data for each method. For the second, the amount of data may differ. Each method will be demonstrated using the data in Table 17.3.5.

**Several Methods—Overlap Test**

**Conditions for Use** Independent data should be obtained for each of the  $k$  methods. *The number of values  $n$  should be the same for each method.*

**Table 17.3.5**

Sample no.	Supplier			
	1	2	3	4
1	45.37	30.05	41.30	46.21
2	21.68	36.04	31.09	36.01
3	43.91	18.04	24.31	46.28
4	47.76*	32.91	15.64	21.80
5	23.81	41.67	54.85*	28.57
6	19.90	37.40	32.96	48.45
7	44.68	46.67*	45.48	33.49
8	11.81	27.93	45.14	53.07*
9	35.42	45.20	45.49	35.65
10	39.85	29.54	52.82	14.95

NOTE: The data are proportional to the time to failure of a standard cutting tool. Asterisks denote largest value in each group.

**Procedure**

1. For each of the  $k$  methods, determine the *largest* value. Label it with an asterisk.

2. Scan the largest values. Label the group with the *largest largest* value as BIG. Label the group with the *smallest largest* value as SMALL, and its largest value as  $S$ .

3. In the group labeled BIG *count* the number of values that are larger than  $S$ , the largest value in SMALL. Denote this count by  $C$ .

4. Enter Table 17.3.6 for  $n$  values of  $k$  groups. If  $C$  exceeds the tabled value, then the data support a conclusion that the methods are different. Otherwise, they do not.

**EXAMPLE.** 1. In Table 17.3.5 the largest value for each of the four groups is marked with an asterisk.

2. Group 3 is BIG. Group 2 is SMALL; the largest value in Group 2 is  $S = 46.67$ .

3. The number of values in Group 3 larger than 46.67 is 2 (52.82, 54.85).

4. Enter Table 17.3.6 with  $n = 10$  and  $k = 4$ . The entry is 5 which is greater than 2. Hence, the data do not support a conclusion that the time to failure for the cutting tools of the four suppliers is measurably different.

**Several Methods—Rank Test**

**Conditions for Use** Independent data should be obtained for each of the methods. The amount of data for each method may be different.

**Procedure**

1. Let  $n_i$  be the number of values in Group  $i$ .

2. Let  $N = \sum_{i=1}^k n_i$  be the total number of values.

3. Rank each value from 1 to  $N$  beginning with the smallest. (If there are ties among  $t$  values, divide the successive ranks equally among them.)

**Table 17.3.6 95% Point for  $k$ -Sample Problems**

$n$	$k$							
	3	4	5	6	7	8	9	10
5	4	4	4	4	4	4	4	4
6	4	4	4	4	5	5	5	5
7	4	5	5	5	5	5	5	5
8	4	5	5	5	5	5	5	5
9	5	5	5	5	5	5	6	6
10	5	5	5	5	6	6	6	6
12	5	5	5	6	6	6	6	6
14	5	5	6	6	6	6	6	6
16	5	5	6	6	6	6	6	6
18	5	6	6	6	6	6	6	7
20	5	6	6	6	6	6	7	7
25	5	6	6	6	6	7	7	7
30	5	6	6	6	7	7	7	7
40	5	6	6	7	7	7	7	7
>40	6	6	7	7	7	7	8	8

NOTE:  $k$  is the number of groups;  $n$  is the number of values per group. For other  $n$ ,  $k$ , and percentage points see Conover (1968).

4. Compute  $r_i$ , the sum of the ranks for the  $i$ th group. [Note: For a check  $\sum_1^k r_i = N(N + 1)/2$ .]

**Test**

1. Compute

$$T = [12/N(N + 1)] \left[ \sum_1^k (r_i^2/n_i) \right] - 3(N + 1)$$

2. Go to Table 17.3.7; find the entry under  $k - 1$ .

If  $T$  exceeds the entry, then the data support the conclusion that the groups are different. Otherwise, they do not.

**Table 17.3.7 Chi-Square Distribution**

$k$	$w$	$k$	$w$
1	3.841	16	26.30
2	5.991	17	27.59
3	7.815	18	28.87
4	9.488	19	30.14
5	11.07	20	31.41
6	12.59	22	33.92
7	14.07	24	36.42
8	15.51	26	38.89
9	16.92	28	41.34
10	18.31	30	43.77
11	19.68	40	55.76
12	21.03	50	67.50
13	22.36	60	79.08
14	23.68	70	90.53
15	25.00	80	101.9

NOTE: Entries are  $P(W > w) = p = 0.05$ . For other values of  $k$  and  $p$ , see Pearson and Hartley (1962).

**EXAMPLE.** We again use the data shown in Table 17.3.5. In Table 17.3.8 the numerical values representing times to failure have been replaced by their ranks. To facilitate such ranking it is convenient to order the values in each group from smallest to largest. Then all values are ranked from smallest to largest. In Table 17.3.8 the values have been reordered this way. The ranks are in parentheses.

1. The number of values in each group is 10. Hence  $n_i = 10$  for each value of  $i$ .
2. The total number of values  $N = 40$ .
- 3 and 4. The sum of the ranks  $r_i$  is shown for each group. [Note that  $\sum r_i = 820 = (40)(41)/2$ .]

$$\begin{aligned} T &= [12/N(N + 1)][\sum(r_i^2/10)] - 3(N + 1) \\ &= [12/(40)(41)][170182/10] - 3(41) \\ &= 124.523 - 123 = 1.523 \end{aligned}$$

Now go to Table 17.3.7 and obtain the entry under  $k = 4 - 1 = 3$ . The entry is 7.815, which is larger than 1.523. Hence, the data do not support a conclusion that the time to failure for the cutting tools for the four suppliers is measurably different.

**Table 17.3.8**

Supplier*			
1	2	3	4
11.81 (1)	18.04 (4)	15.64 (3)	14.95 (2)
19.90 (5)	27.93 (10)	24.31 (9)	21.80 (7)
21.68 (6)	29.54 (12)	21.09 (14)	28.57 (11)
23.81 (8)	30.05 (13)	32.96 (16)	33.49 (17)
35.42 (18)	32.91 (15)	41.30 (24)	35.65 (19)
39.85 (23)	36.04 (21)	45.14 (28)	36.01 (20)
43.91 (26)	37.40 (22)	45.48 (31)	46.21 (33)
44.68 (27)	41.67 (25)	45.49 (32)	46.28 (34)
45.37 (30)	45.20 (29)	52.82 (38)	48.45 (37)
47.76 (36)	46.67 (35)	54.85 (40)	53.07 (39)
180	186	235	219 $r_i$
32400	34596	55225	47961 $r_i^2$

\* These are the data of Table 17.3.5 with the values for each supplier listed from smallest to largest. The values in parentheses are the ranks of the time to failure values from smallest to largest.

**GO/NO-GO DATA**

Quite often the data that we encounter will be **attribute or go/no-go data**; that is, we will not have quantitative measurements but only a characterization as to whether an item does or does not have some attribute. For example, if a manufactured part has a specification that it should not be shorter than 2 in, we might construct a template; and if a part is to meet the specification, it should not fit into the template. After inspecting a series of units with the template our data would consist of a tabulation of "gos" and "no-gos"—those that did not meet the specification and those that did.

If the items that are checked for an attribute are obtained by random sampling, the resulting data will follow what is known as the **binomial distribution**. Its standard form is as follows:

$p$  is the long-term fraction of failures  
 $q = 1 - p$  is the long-term fraction of successes  
 $n$  is the size of the random sample.

Then the probability that our sample gives  $x$  failures and  $n - x$  successes is

$$f(x;n, p) = \binom{n}{x} p^x q^{n-x}; x = 0, 1, 2, \dots, n$$

where  $\binom{n}{x} = n!/x!(n - x)!$

From  $f(x; n, p)$ , for a given  $n$  and  $p$ , we can calculate the probability of  $x$  failures in a sample size  $n$ . Similarly, by summing terms for different values of  $x$ , we can calculate the probability of having more than  $w$  failures or fewer than  $r$  failures, etc. Here we are not going to try to be so precise; rather we are going to try to show the general picture of the relationship between  $x$ ,  $p$ , and  $n$  by the use of examples and the graph in Fig. 17.3.2.

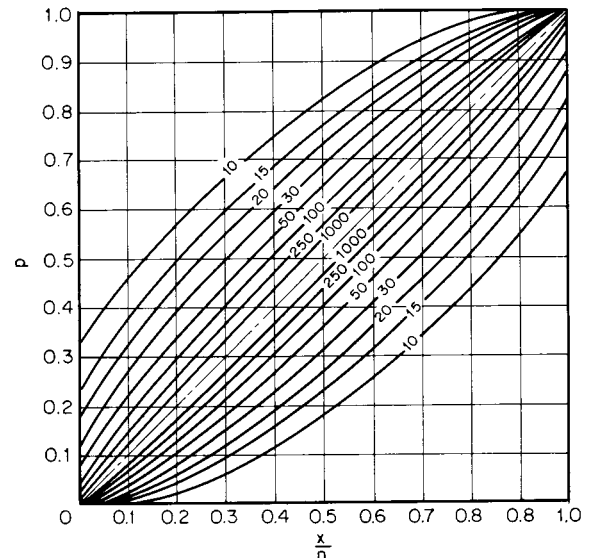

**Fig. 17.3.2** Binomial distribution, 95 percent confidence bands. (Reproduced with the permission of the Biometrika Trust from C. J. Clopper and E. S. Pearson, "The Use of Confidence or Fiducial Limits Illustrated in the Case of the Binomial," *Biometrika*, 26 (1934), p. 410.)

**Estimating the Failure Rate**

In a manufacturing process a general index of quality is the fraction of items which fail to pass a certain test. Suppose that we take a random sample of size  $n = 100$  from the process and observe  $x_0 = 10$  failures. Clearly we have met the conditions for a binomial distribution and an estimate of  $p$ , the long-term failure rate is  $\hat{p} = x_0/n = 10/100 = 0.1$ .

## 17-24 ENGINEERING STATISTICS AND QUALITY CONTROL

However, we would also like to know the accuracy of the estimate. In other words, if we operate the process for a long time under these conditions and obtain a large sample, what might be the value of  $p$ ? One simple way to assess the estimate of  $\hat{p}$  is to find values  $p_1$  and  $p_2$  ( $p_1 < p_2$ ) such that the following probabilities are satisfied for a fixed value of  $\alpha$ :

$$\begin{aligned} \Pr[x \geq x_0 | p_1] &= \alpha/2 \\ \Pr[x \leq x_0 | p_2] &= \alpha/2 \end{aligned}$$

These values are the solutions for  $p$  of the two equations.

$$\begin{aligned} \sum_{x=x_0}^n \binom{n}{x} p_1^x (1-p_1)^{n-x} &= \alpha/2 \\ \sum_{x=0}^{x_0} \binom{n}{x} p_2^x (1-p_2)^{n-x} &= \alpha/2 \end{aligned}$$

General solutions for these equations for  $\alpha = 0.05$  are shown in Fig. 17.3.2. If we go to Fig. 17.3.2 with  $x/n = 0.1$  and read where the lines for  $n = 100$  intersect the ordinate or  $p$  scale, we see that  $p_1 = 0.07$  and  $p_2 = 0.18$ . We can then state that we have reasonable confidence (the probability is 0.95) that the long-term failure rate for the process is between 0.07 and 0.18.

### Estimating the Sample Size

It should be evident that Fig. 17.3.2 can also be used to determine how large a sample is needed to estimate a proportion or a percentage with a specific accuracy or tolerance. Suppose that the proportion of interest is assumed to be around  $p = 0.20$ . Now enter Fig. 17.3.2 with  $x/n = 0.20$ . From the figure we see that if we take a sample of size 50, our estimate will have a range of about  $\pm 0.10$  (actually  $-0.10, +0.13$ ). On the other hand, if the sample size is 250, the estimate will have a range of about  $\pm 0.06$ .

Often one wants to compare the performance of two processes. As above, suppose that the rate  $p$  for our process is 0.20. We have a modification that we want to test; however, to be economical the modification has to bring the rate  $p$  down to 0.15 or less. If the modification is going to be assessed on the  $p$ 's for the standard and the modification, then we do not want the uncertainty in their estimates to overlap and the uncertainty should be less than half of 0.05 where  $0.05 = (0.20 - 0.15)$ . Figure 17.3.2 shows that we would have to use a sample size of at least 1000. This demonstrates that attribute sampling is effective only when the items and their characterization are not expensive. Otherwise, it is best to go to measurements where smaller sample sizes can be used to assess differences.

A more detailed exposition of the binomial distribution and its uses can be found in Brownlee (1970).

### CONTROL CHARTS

When an industrial process is under control it is in a state of "statistical equilibrium." By equilibrium we mean that we can characterize its output by a fixed average  $\mu$  and a fixed standard deviation  $\sigma$ . The variation in output is what one would expect to see from that  $\mu$  and  $\sigma$ , as

bounded by the values given in Tchebysheff's theorem, let us say. However, if control is lost, we tend to get a greater spread in values. In effect, the average  $\mu$  or the standard deviation  $\sigma$  is changing because of some cause. The causes of lack of control are manifold—it can be a change in raw materials, tool wear, instrumentaton failure, operator error, etc. The important thing is that one wants to be able to detect when this lack of control occurs and take the appropriate steps to make corrections.

One of the most frequently used statistical tools for analyzing the state of an industrial process is the control chart. The two most commonly used charts are those for the **average** and the **range**. The control chart procedure consists of these steps:

1. Choose a characteristic  $X$  which will be used to describe the product coming from the process.
2. At time  $t_i$ , take a small number of observations  $n$  on the process. The number  $n$  should be small enough so that it is reasonable to assume that conditions will not change during the course of obtaining the observations.
3. For each set of  $n$  observations, compute the average  $\bar{x}_i$  and the range  $r_i$  as defined in the section "Characterizing Observational Data."

There are two different control situations of interest.

4a. *Control standards given.* Suppose that from past operation of the process or from the need to meet certain specifications, a goal average  $\mu^*$  and a goal standard deviation  $\sigma^*$  are specified. Then we set up two charts as follows:

$$\begin{array}{ll} \text{Average chart:} & \begin{array}{l} \text{Upper limit line: } \mu^* + A\sigma^* \\ \text{Central line: } \mu^* \\ \text{Lower limit line: } \mu^* - A\sigma^* \end{array} \\ \text{Range chart:} & \begin{array}{l} \text{Upper limit line: } D_2\sigma^* \\ \text{Central line: } d\sigma^* \\ \text{Lower limit line: } D_1\sigma^* \end{array} \end{array}$$

The values of  $A$ ,  $d$ ,  $D_1$ , and  $D_2$  depend upon  $n$  and can be found in Table 17.3.9.

Plot the values of  $\bar{x}_i$  and  $r_i$  obtained in (3) on the two charts as shown in Fig. 17.3.3. Whenever a value falls outside the limit lines, there is an indication of lack of control, and one is justified in seeking the causes for a change.

4b. *Control, no standards given.* Often one has no prior information about the process  $\mu$  and  $\sigma$ , and one wants to determine if the process behaves as though it is in statistical equilibrium, and if not, take actions to get it there. In this case one has to determine the central lines for the charts from process data. To do this one first accumulates the data for 25 to 50 time periods as indicated in (2). Then two charts are set up as follows: Let  $K$  be the 25 to 50 time periods observed. Compute an overall average  $\bar{X} = \sum_{i=1}^K \bar{x}_i / K$  and the average range  $\bar{R} = \sum_{i=1}^K r_i / K$ . Set up charts with limits defined from:

$$\begin{array}{ll} \text{Average chart:} & \begin{array}{l} \text{Upper limit line: } \bar{X} + A_2\bar{R} \\ \text{Central line: } \bar{X} \\ \text{Lower limit line: } \bar{X} - A_2\bar{R} \end{array} \\ \text{Range chart:} & \begin{array}{l} \text{Upper limit line: } D_4\bar{R} \\ \text{Central line: } \bar{R} \\ \text{Lower limit line: } D_3\bar{R} \end{array} \end{array}$$

Table 17.3.9 Factors for Control-Chart Limits

Sample size $n$	For averages			For ranges			
	$A$	$A_2$	$d$	$D_1$	$D_2$	$D_3$	$D_4$
2	2.12	1.88	1.128	0	3.69	0	3.27
3	1.73	1.02	1.693	0	4.36	0	2.57
4	1.50	0.73	2.059	0	4.70	0	2.28
5	1.34	0.58	2.326	0	4.92	0	2.11
6	1.22	0.48	2.534	0	5.08	0	2.00
7	1.13	0.42	2.704	0.21	5.20	0.08	1.92
8	1.06	0.37	2.847	0.39	5.31	0.14	1.86
9	1.00	0.34	2.970	0.55	5.39	0.18	1.82
10	0.95	0.31	3.078	0.69	5.47	0.22	1.78



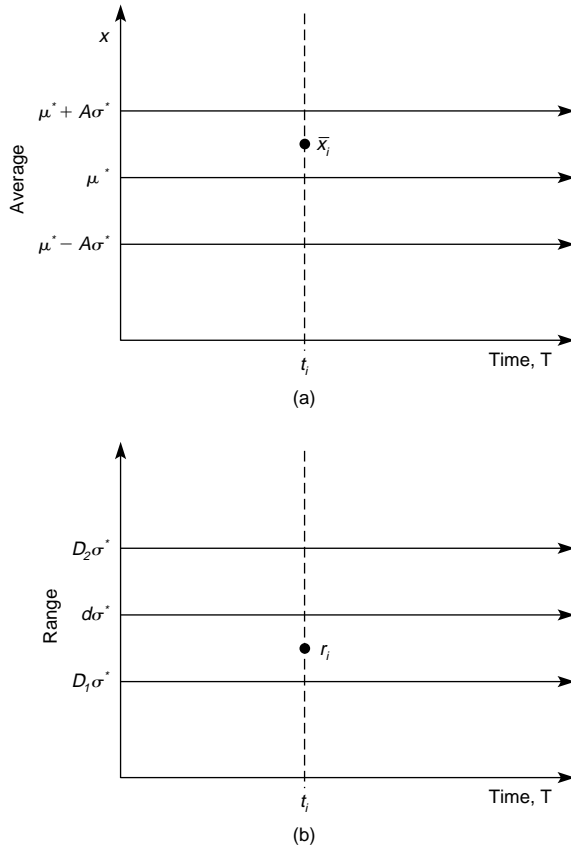

Fig. 17.3.3 Control chart. (a) Average chart; (b) range chart.

The values of  $A_2$ ,  $D_3$ , and  $D_4$  depend upon  $n$  and can be found in Table 17.3.9. The individual  $\bar{x}_i$  and  $r_i$  are plotted on the charts, and again a value outside the limits is an indication of lack of control and is justification for seeking the cause for a change.

#### Process Capability Indices

If the process is in statistical control, an estimate for the process standard deviation can be obtained by using

$$\hat{\sigma} = \bar{R}/d$$

In turn,  $\hat{\sigma}$  is used to calculate the **process capability indices**  $C_p$  and  $C_{pk}$ . These two indices compare the actual spread of the data with the desired range (usually as specified by a customer).  $C_p$  is used when the actual process average is equal to the goal average.  $C_{pk}$  is used when the actual process average is not equal to the goal average. The desired range is called the **specification tolerance (ST)** and is equal to the upper specification limit minus the lower specification limit, namely,  $2A\sigma^*$ .

$C_p$  is given by the following equation:

$$C_p = ST/6\hat{\sigma} = 2A\sigma^*/6\hat{\sigma}$$

If  $C_p \geq 1$ , the process is considered to be capable, which means that most or all of the data stayed within the desired range. If  $C_p < 1$ , the process is considered to be not capable and requires adjustment. Ideally, one should control the process variability so that  $C_p \geq 2$ .

The other index,  $C_{pk}$ , is given by

$$C_{pk} = C_p(1 - k)$$

where  $k = 2(\mu^* - \bar{X})/ST = (\mu^* - \bar{X})/A\sigma^*$

and  $\bar{X} = \sum \bar{x}_i/K$

The  $(1 - k)$  factor modifies  $C_p$  so as to allow the actual average  $\bar{X}$  to be different from the goal average  $\mu^*$ . Ideally, one should control the process so that  $C_{pk} \geq 1.5$ . In process capability analysis, the indices should be calculated on a frequent basis, but the trends should be examined only monthly or quarterly in order to be meaningful.

#### Charts for Go/No-Go Data

The control chart concept can also be used for attribute or go/no-go data. The procedures are, in general, the same as outlined for averages and ranges. Briefly, they are as follows:

1. Select a sample of size  $n$  from the process; for best results  $n$  should be in the range of 50 to 100.
2. Let  $x_i$  denote the number of defective units in the sample of size  $n$  at time  $t_i$ ; then  $\hat{p}_i = x_i/n$  is an estimate of the process fraction defective.
3. Set control limits for a standard fraction defective  $p^*$  at

$$p^* \pm 3[p^*(1 - p^*)/n]^{1/2}$$

If no standard is given, then take  $K = 25$  to 50 samples of size  $n$  to get a good estimate of the fraction-defective  $p$ . Define  $\bar{p} = \sum_{i=1}^K \hat{p}_i/K$ . In this case set control limits at

$$\bar{p} \pm 3[\bar{p}(1 - \bar{p})/n]^{1/2}$$

4. Interpret a  $\hat{p}_i$  outside the limits as an indication of a change worthy of investigation.

Further information on control charts can be found in Duncan (1986).

## 17.4 METHODS ENGINEERING

by Vincent M. Altamuro

REFERENCES: ASME Standard Industrial Engineering Terminology. Barnes, "Motion and Time Study," Wiley. Krick, "Methods Engineering," Wiley. Maynard, Stegemerten, and Schwab, "Methods-Time-Measurement," McGraw-Hill.

#### SCOPE OF METHODS ENGINEERING

Methods engineering is concerned with the selection, development, and documentation of the methods by which work is to be done. It includes the analysis of input and output conditions, assisting in the choice of the processes to be used, operations and work flow analyses, workplace design, assisting in tool and equipment selection and specifications,

ergonomic and human factors considerations, workplace layout, motion analysis and standardization, and the establishment of work time standards. A primary concern of methods engineering is the integration of humans and equipment in the work processes and facilities.

#### PROCESS ANALYSIS

Process analysis is that step in the conversion of raw materials to a finished product at which decisions are made regarding what methods, machines, tools, inspections and routings are best. In many cases, the product's specifications can be altered slightly, without diminishing its function or quality level, so as to allow processing by a preferred

## 17-26 METHODS ENGINEERING

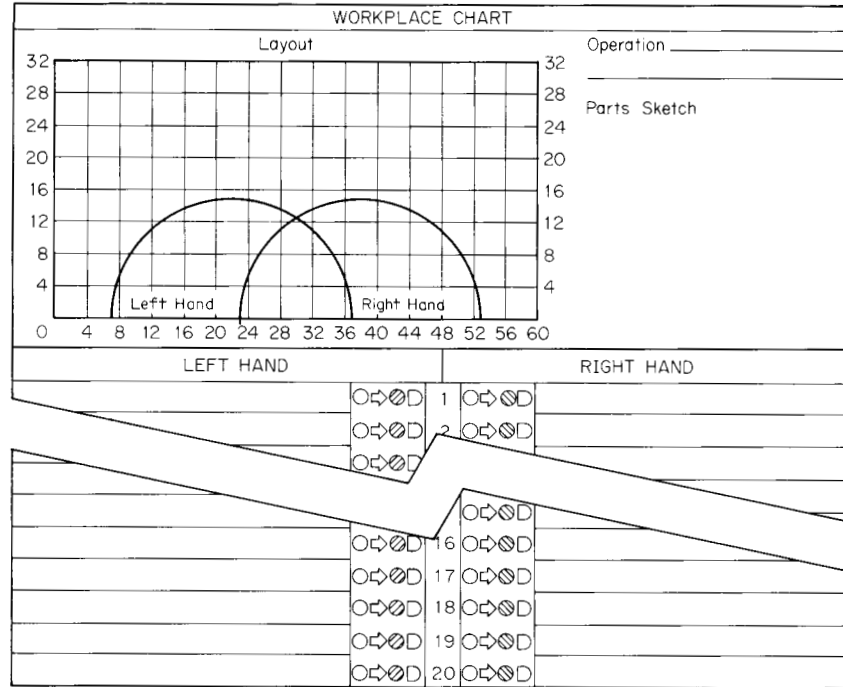

Fig. 17.4.1 Workplace layout chart.

method. For this reason, it is desirable to have the product's designer and the process engineer work together before specifications are finalized.

### WORKPLACE DESIGN

Material usually flows through a facility, stopping briefly at stations where additional work is done on it to bring it closer to a finished product. These workstations, or workplaces, must be designed to permit performance of the required operations, to contain all the tooling and equipment needed to fit the capabilities and limitations of the people working at them, to be safe and to interface smoothly with neighboring workplaces.

Human engineering and ergonomic factors must be considered so that all work, tools, and machine activation devices are not only within the comfortable reach of the operator but are designed for safe and efficient operation. A workplace chart (Fig. 17.4.1) which analyzes the required actions of both hands is an aid in workplace design.

### METHODS DESIGN

Methods design is the analysis of the various ways a task can be done so as to establish the one best way. It includes *motion analysis*—the study of the actions the operator can use and the advantages and/or disadvantages of each variation—and *standardization of procedure*—the selection and recording of the selected and authorized work methods.

While "time and motion study" is the more commonly used term, it is more correct to use "motion and time study," as the motion study to establish the standard procedure must be done prior to the establishment of a standard time to perform that work.

According to ASME Standard Industrial Engineering Terminology, motion study is defined as

... the analysis of the manual and the eye movements occurring in an operation or work cycle for the purpose of eliminating wasted movements and establishing a better sequence and coordination of movements.

In the same publication, time study is defined as

... the procedure by which the actual elapsed time for performing an operation or subdivisions or elements thereof is determined by the use of a suitable timing device and recorded. The procedure usually but not always includes the adjustment of the actual time as the result of performance rating to derive the time which should be required to perform the task by a workman working at a standard pace and following a standard method under standard conditions.

Attempts have been made to separate the two functions and to assign each to a specialist. Although motion study deals with method and time study deals with time, the two are nearly inseparable in practical application work. The method determines the time required, and the time determines which of two or more methods is the best. It has, therefore, been found best to have both functions handled by the same individual.

### ELEMENTS OF MOTION AND TIME STUDY

Figure 17.4.2 presents graphically the steps which should be taken to make a good motion and time study and shows their relation to each other and the order in which they must be performed.

### METHOD DEVELOPMENT

The first step is the development of the method. Starting with the drawing of the product, the operations which must be performed are determined and tools and equipment are specified. In large companies, this is usually done by a specialist called a process engineer. In smaller companies, processing is commonly done by the time study specialist.

Next, the detailed method by which each operation should be performed is developed. The procedures used for this are known as operation analysis and motion study.

### OPERATION ANALYSIS

Operation analysis is the procedure employed to study all major factors which affect a given operation. It is used for the purpose of uncovering possibilities of improving the method. The study is made by reviewing the operation with an open mind and asking either of oneself or others

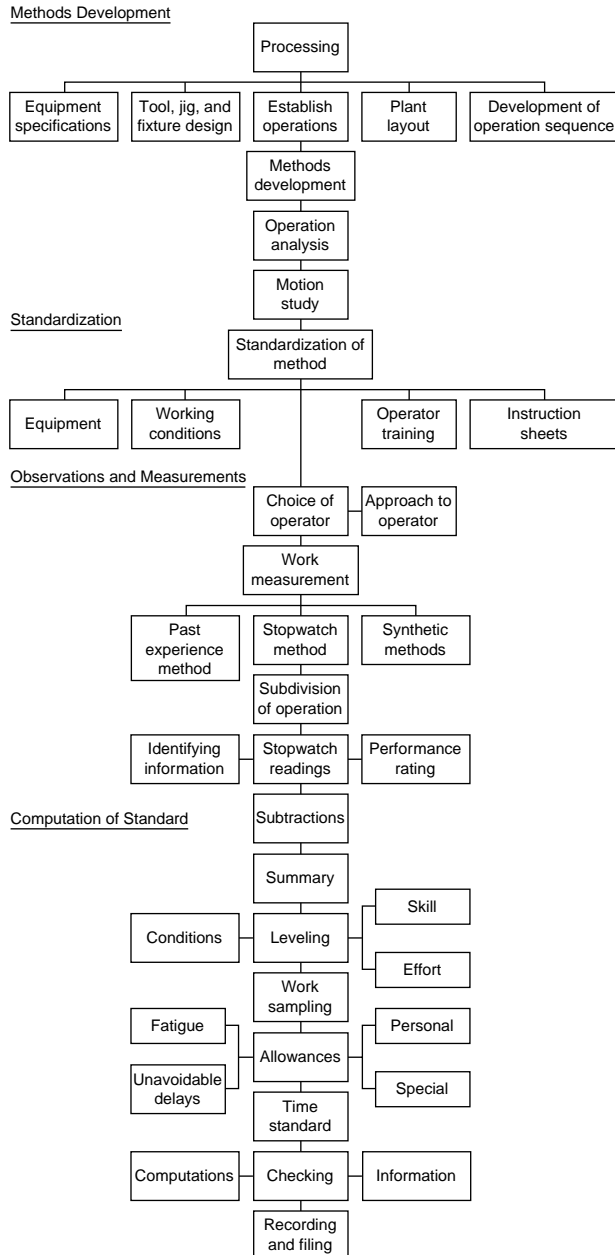

Fig. 17.4.2 Graphic analysis of the elements of motion and time study.

questions which are likely to lead to methods-improving ideas. If this is done systematically, so that the possibility of overlooking factors which should be considered is minimized, worthwhile improvements are almost certain to result.

The 10 major factors explored during operation analysis, together with typical questions which should be asked about each factor, are as follows:

1. Purpose of operation
  - a. Is the result accomplished by the operation necessary?
  - b. Can the purpose of the operation be accomplished better in any other way?

2. Design of part
  - a. Can motions be eliminated by design changes which will not affect the functioning and other desirable characteristics of the product?
  - b. Is the design satisfactory for automated assembly?
3. Complete survey of all operations performed on part
  - a. Can the operation being analyzed be eliminated by changing the procedure or the sequence of operations?
  - b. Can it be combined with another operation?
4. Inspection requirements
  - a. Are tolerance, allowance, finish, and other requirements necessary?
  - b. Will changing the requirements of a previous operation make this operation easier to perform?
5. Material
  - a. Is the material furnished in a suitable condition for use?
  - b. Is material utilized to best advantage during processing?
6. Material handling
  - a. Where should incoming and outgoing material be located with respect to the work station?
  - b. Can a progressive assembly line be set up?
7. Workplace layout, setup, and tool equipment
  - a. Does the workplace layout conform to the principles of motion economy?
  - b. Can the work be held in the machine by other means to better advantage?
8. Common possibilities for job improvement
  - a. Can "drop delivery" be used?
  - b. Can foot-operated mechanisms be used to free the hand for other work?
9. Working conditions
  - a. Has safety received due consideration?
  - b. Are new workers properly introduced to their surroundings, and are sufficient instructions given them?
10. Method
  - a. Is the repetitiveness of the job sufficient to justify more detailed motion study?
  - b. Should full automation be considered?

When the method has been developed, conditions are standardized, and the operators are trained to follow the approved method.

At this time, not before, the job is ready for time study. Suitable operators are selected, the purposes of the study are carefully explained to them, and the time study observations are made. During the study, time study specialists rate the performance being given by operators either by judging the skill and effort they are exhibiting or by assessing the speed with which motions are made as compared with what they consider to be a normal working pace. The final step is to compute the standard.

#### PRINCIPLES OF MOTION STUDY

Operation analysis is a primary analysis which eliminates inefficiencies. Motion study is a secondary analysis which refines the method still further. Motion study may and often does suggest further improvements in the factors considered during operation analyses, such as tools, material handling, design, and workplace layouts. In addition, it studies the human factors as well as the mechanical and sets up operations in conformance with the limitations, both physical and psychological, of those who must perform them.

The technique of motion study rests on the concept originally advanced by Frank B. and Lillian M. Gilbreth that all work is performed by using a relatively few basic operations in varying combinations and sequences. These Gilbreth Basic Elements have also been called "therbligs" and "basic divisions of accomplishment."

The basic elements together with their symbols (for definitions see ASME Industrial Engineering Terminology), grouped in accordance with their effect on accomplishment, are as follows:

## 17-28 METHODS ENGINEERING

Group 1 Accomplishes	
Reach	R
Move	M
Grasp	G
Position	P
Disengage	D
Release	RL
Examine	E
Do	DO
Group 2 Retards accomplishment	
Change direction	CD
Preposition	PP
Search	S
Select	SE
Plan	PL
Balancing delay	BD
Group 3 Does not accomplish	
Hold	H
Avoidable delay	AD
Unavoidable delay	UD
Rest to overcome fatigue	F

Group 1 is the useful group of basic elements or the ones that accomplish work. They do not necessarily accomplish it in the most effective way, however, and a study of these elements will often uncover possibilities for improvement.

Group 2 contains the basic elements that tend to retard accomplishment when present. In most cases, they do this by slowing down the group 1 basic elements. They should be eliminated wherever possible.

Group 3 is the nonaccomplishment group. The greatest improvements in method usually come from the elimination of the group 3 basic elements from the cycle. This is done by rearranging the motion sequence, by providing mechanical holding fixtures, and by improving the workplace layout.

An operation may be analyzed into its basic elements either by observation or by making a micromotion study of a motion picture of the operation.

Methods improvement may be made on any operation by eliminating insofar as possible the group 2 and group 3 basic elements and by arranging the workplace so that the group 1 basic elements are performed in the shortest reasonable time. In doing this, certain laws of motion economy are followed. The following, derived from the laws originally stated by the Gilbreths, are the most important.

1. When both hands begin and complete their motions simultaneously and are not idle during rest periods, maximum performance is approached.
2. When motions of the arms are made simultaneously in opposite directions over symmetrical paths, rhythm and automaticity develop most naturally.
3. The motion sequence which employs the fewest basic elements is the best for performing a given task.
4. When motions are confined to the lowest practical classification, maximum performance and minimum fatigue are approached. Motion classifications are: Class 1, finger motions; Class 2, finger and wrist motions; Class 3, finger, wrist, and forearm motions; Class 4, finger, wrist, forearm, and upper-arm motions; Class 5, finger, wrist forearm, upper-arm, and body motions.

### STANDARDIZING THE JOB

When an acceptable method has been devised, equipment, materials, and conditions must be standardized so that the method can always be followed. Information and records describing the standard method must be carefully made and preserved, for experience has shown that, unless this is done, minor variations creep in which may in time cause a major

problem. In the case of repetitive work, a job is not standardized until each piece is delivered to operators in the same condition, and it is possible for them to perform their work on each piece by completing a set cycle of motions, doing a definite amount of work with the same equipment under uniform working conditions.

The operator or operators must then be taught to follow the approved method. Operator training is always important if reasonable production is to be obtained, but it is an absolute necessity where methods have been devised by motion study. It is quite apparent that the operators cannot be expected to discover for themselves the method which the time-study specialist developed as the result of hours of concentrated study. They must, therefore, be carefully trained if they are to be expected to reach standard production. In addition, an accurate time study cannot be made until the operator is following the approved method with reasonable proficiency.

### WORK MEASUREMENT

Work measurement is the calculation of the amount of time it should take to do a standardized job. It utilizes the concept of a standard time. The standard time to perform a task is the agreed-upon and reproducible calculated time that a hypothetical typical person working at a normal rate of speed should take to do the job using the specified method with the proper tools and materials. It is the normal time determined to be required to complete one prescribed cycle of an operation, including noncyclic tasks, allowances, and unavoidable delays.

**Time Study Methods** There are several bases upon which time standards may be calculated. They include:

1. *Application of past experience.* The time required to do the operation in the past, either recorded or remembered, may be used as the present standard or as a basis for estimating a standard for a similar operation or the same operation being done under changed conditions.
2. *Direct observation and measurement.* The operation may be observed and its time recorded as it is actually performed and adjustments may be made to allow for the estimated pace rate of the operator and for special allowances. A stop watch or other recording instrument may be used or work sampling may be employed, which makes statistical inferences based upon random observations.
3. *Synthetic techniques.* A time standard for an actual or proposed operation may be constructed from the sum of the times to perform its several components. The times of the components are extracted from standard charts, tables, graphs, and formulas in manuals or in computer databases and totaled to arrive at the overall time for the entire operation. Standard data or predetermined motion times may be used. Methods-time measurement (MTM), basic-motion times (BMT), work factor (WF), and others are some of the systems available.

### TIME STUDY OBSERVATIONS

The time study specialist can study any operator he or she wishes so long as that operator is using the accepted method. By applying what is known as the leveling procedure, the time study specialist should arrive at the same final time standard regardless of whether studying the fastest or the slowest worker.

The manner in which the operator is approached at the beginning of the study is important. This is particularly true if the operator is not accustomed to being studied. Time study specialists should be courteous and unassuming and should show a recognition of and a respect for the problems of the operator. They should be frank in their dealings with the operator and should be willing at any time to explain what they are doing and how they do it.

The first step in making time study observations is to subdivide the operation into a number of smaller operations which will be studied and timed separately. These subdivisions are known as elements, or elemental operations. Each element is exactly described in a few well-chosen words, which are recorded on the top of the time study form. Figure 17.4.3 shows how this is done. The beginning and ending points of these elements must be clearly recognizable so that the chances of overlapping watch readings will be minimized.



17-30 METHODS ENGINEERING

STUDY No. 1 DATE 1-18-94

OPERATION \_\_\_\_\_ DWG. 22289 SUB. 1

DEPARTMENT Mill Slot MOULD \_\_\_\_\_ DIE \_\_\_\_\_ STYLE \_\_\_\_\_ ITEM 1

DEPARTMENT 10 OPERATOR \_\_\_\_\_ PATTERN 9341-A INS. SPEC. \_\_\_\_\_ L. SPEC. \_\_\_\_\_ SUB \_\_\_\_\_

MAN NAME Gross NO. 33 PART DESCRIPTION Clamp for Regulator Type X-4

EQUIPMENT #3 Le Blond Horizontal Milling Machine MATERIAL \_\_\_\_\_

No.	ELEMENTS	SMALL TOOL NOS. FEED SPEED, DEPTH OF CUT, ETC	ELEMENTAL TIME ALLOWED (BOTTOM LINE OR OTHER SIDE)	OCCURRENCES PER PIECE OR CYCLE
1	MACHINE TOOL No. <u>3589</u>			<u>00078</u>
2	SPECIAL TOOLS, JIGS, FIXTURES, ETC. <u>6" dia. spl. side cutter</u>			<u>00087</u>
3				<u>00207</u>
4				<u>00035</u>
5	CONDITIONS <u>Some castings have rough spots on sides which make them hard to hold in vise. Material supply light, temperature and ventilation av.</u>			<u>00129</u>
6				<u>00033</u>
7				<u>00800</u>
8	OBSERVER _____ APPROVED BY _____			<u>00162</u>
9	SKETCH			<u>00125</u>
10				<u>00131</u>
11				<u>00091</u>
12				<u>00091</u>
		TIME ALLOWED, SET UP	EACH PIECE	TOTAL <u>0202</u>
REMARKS: <u>Operator removes parts from top pan and places them on table while machine is making cut. He also cleans cuttings from table at this time. Cutting speed for this line of work is held constant at 140 RPM. Feed varies with width and depth of cut. On this job, feed = 6"/min</u>				

OBSERVATION SHEET

Fig. 17.4.4 Back of a time study form.

If all operators available for study worked at the average performance level, the task of establishing a standard would be easy. It would be necessary merely to average the elapsed elemental times determined from time study and add an allowance for fatigue and personal and unavoidable delays. It is seldom, however, that a performance is observed which is rated throughout as average. Therefore, to establish a standard which represents the time which would be taken had an average performance been observed, it is necessary to use some method of adjusting the recorded elemental times when other than average performance is timed.

One of the well-known methods of doing this is the **leveling procedure**. When properly applied it gives excellent results. It must be correctly understood, of course, and the time study specialist who uses it must be thoroughly trained to apply it correctly.

The procedure recognizes that when the correct method is being followed, skill, effort, and working conditions will affect the level at which

the operator works. These factors are judged during the making of the time study. Skill is defined as *proficiency at following a given method*. This is not subject to variation at will by the operator but develops with practice over a period of time. Effort is defined as *the will to work*. It is controllable by the operator within the limits imposed by skill. Conditions are those conditions which affect the operator and not those which affect the method.

Definitions have been established for different degrees of skill, effort, and conditions. Numerical factors have been established by extensive research for each degree of skill, effort, and conditions. These are shown by Fig. 17.4.5. The algebraic sum of these numerical values added to 1.0 gives the leveling factor by which all actual elemental times are multiplied to bring them to the average or normal level. The leveling factor represents in effect the amount in percent which actual performance times are above and below the average performance level.

Skill	Conditions	Effort
+0.15 A1 Superskill	+0.06 A Ideal	+0.13 A1 Excessive
+0.13 A2	+0.04 B Excellent	+0.12 A2
+0.11 B1 Excellent	+0.02 C Good	+0.10 B1 Excellent
+0.08 B2	0.00 D Average	+0.08 B2
+0.06 C1 Good	-0.03 E Fair	+0.05 C1 Good
+0.03 C2	-0.07 F Poor	+0.02 C2
0.00 D Average		0.00 D Average
-0.05 E1 Fair		-0.04 E1 Fair
-0.10 E2		-0.08 E2
-0.16 F1 Poor		-0.12 F1 Poor
-0.22 F2		-0.17 F2

Fig. 17.4.5 Leveling factors for performance rating.

#### ALLOWANCES FOR FATIGUE AND PERSONAL AND UNAVOIDABLE DELAYS

The leveled elemental time values are net elapsed times adjusted to the average performance level. They do not provide for delays and other legitimate allowances. Something, therefore, must be added to take care of such things as fatigue, and special conditions of the work.

Fatigue allowances vary according to the nature of the work. Flat percentages are determined for each general class of work, such as bench work, machine-tool operation, hard physical labor, and so on. Personal allowances are the same for most classes of work. Unavoidable delay allowances vary with the nature of the work and the conditions under which it is performed. Peculiar conditions surrounding specific jobs sometimes require additional special allowances.

It is apparent, therefore, that the proper allowance factor to use can only be determined by a study of the class of work to which it is to be applied. Allowances are determined either by a series of all-day time studies or by a statistical method known as work sampling, or both. When an allowance factor has once been established, it is then applied to all time studies made on that class of work thereafter.

#### DEVELOPING THE TIME STANDARD

When time study observations have been completed, a series of calculations are made to develop the time standard. Elapsed times are determined by subtracting successive watch readings. Each subtraction is recorded between the two watch readings that determine its value. Elapsed time is noted in ink to ensure a permanent record and to distinguish it from the watch readings which are usually recorded in pencil. A study of Fig. 17.4.3 will show how subtractions are entered on the time study form and later summarized.

The several elapsed times for each element are next carefully compared and examined for abnormal values. If any are found, they are circled so that they can be distinguished and excluded from the summary.

The remaining elapsed times for each element are added and are averaged by dividing by the number of elapsed time readings. The results are average elapsed times which represent the time taken by the operator during that particular study. These times must be adjusted by multiplying them by a leveling factor to bring them to the average performance level. This factor is determined by the rating of skill, effort, and conditions made during the period of observation.

Each average elapsed time is multiplied by the leveling factor, except when the element is not controlled by the operator. An element that is outside the control of the operator, such as element 7 in Fig. 17.4.3 which is a cut with power feed, should not be leveled, because it is unaffected by the ability of the operator. As long as the proper feed and speed are used, the time for performing this element will be the same whether the worker is an expert or a learner.

If workers were able to work continuously, the leveled time would be the correct value to allow for doing the operation studied, but constant application to the job is neither possible nor desirable. In the course of a day, there are certain to be occasional interruptions and delays, for which due allowance must be made in establishing the final standard. Therefore, each elemental time is increased by an allowance which covers time that will be consumed by personal and unavoidable delays, fatigue, and any special factors that may affect the job.

The numbers and descriptions of the elemental operations together with their allowed time are transcribed on the back of the time study form as shown by Fig. 17.4.4. The number of times an elemental operation occurs on each piece or cycle of the operation is taken into account, and the total time allowed for each element is determined and recorded. The final standard for the operation is the sum of the amounts recorded in the "time-allowed" column. When all computations have been checked and all supporting records have been properly identified and filed, the task of developing the time standard is complete.

#### TIME FORMULAS AND STANDARD DATA

On repetitive work, time study is a satisfactory tool of work measurement. A single time study may be sufficient to establish a standard which will cover the work of one or more operators for a long period of time.

As quantities become smaller, however, the cost of establishing standards by individual time study increases until at length it becomes prohibitive. In the extreme case, where products are manufactured in quantities of one, it would require at least one time study specialist for each operator if standards were established by detailed time study, and the standards would not be available until after the jobs had been completed.

In order to simplify the task of setting standards on a given class of work and in order to improve the consistency of the standards, standard data are frequently used by time study specialists. A compilation of standard data in its simplest form is merely a list of all the different elements that have occurred during all the time studies made on a given class of work, with representative time values for each element. Every element that differs even slightly from any other element has its own time value.

When a job comes into the shop on which no standard has previously been established, time study specialists analyze the job either mentally or by direct observation and determine the elements required to perform it. They then select time values from the standard data for each element. Their sum gives the standard for the job.

This method, although a decided improvement from a time, cost, and consistency standpoint over individual time study, is capable of further refinement and improvement. On a given class of work, certain elements will be performed—for example, "pick up part"—on every piece produced, while others—such as "secure in steady rest"—will be performed only when a piece has certain characteristics. In some cases, the performance of a certain element will always require the performance of another element, e.g., "start machine" will always require the subsequent performance of the element "stop machine." Then again, the time for performing certain elements—for example, "engage feed"—will be the same regardless of the characteristics of the part being worked upon, while the time for performing certain other elements—like "lay part aside"—will be affected by the size and shape of the part.

Thus it is possible to make certain combinations and groupings which will simplify the task of applying standard data. Time study specialists construct various charts, and tables which they still call standard data, or, in the ultimate refinement, develop time formulas. A time formula is a convenient arrangement of standard data which simplifies their accurate application. Much of the analysis which is necessary when applying standard data is done once and for all at the time the formula is derived. The job characteristics which make the performance of certain elements or groups of elements necessary are determined, and the formula is expressed in terms of these characteristics.

Figure 17.4.3 illustrates a detailed time study made to establish a standard on a simple milling machine operation. The same standard can be derived much more quickly from the following time formula:

$$\text{Curve } A + \text{Table } T = \text{each piece time}$$

Curve A combines the times for the variable elements "pick up part from table," "place in vise," and "lay aside part in tote pan" with the times for the constant elements "tighten vise," "start machine," "run table forward 4 in," "engage feed," "stop machine," "release vise," and "brush vise." Table T combines the times for "mill slot" and "return table." The standard time for milling a slot in a brass clamp of any size is computed by determining the variable characteristics of the job from the drawing—in this case, the volume of the clamp and the perimeter of the cut—and adding together the time read from curve A and the time read from Table T.

The amount of time which the use of time formulas will save the time study specialist is readily apparent. It takes a certain amount of time and no little know-how to develop a time formula, but once it is available,

## 17-32 COST OF ELECTRIC POWER

the job of establishing accurate standards becomes a simple, fairly routine task. The time required to make and work up a time study will be from 1 to 100 or more hours, depending upon the length of the operation cycle studied. The time required to establish a standard from a time formula will, in the majority of cases, range from 1 to 15 min, depending upon the complexity of the formula and the amount of time required to determine the characteristics of the job. Where all the necessary information may be obtained from the drawing of the part, the standard may generally be computed in less than 5 min.

### USES OF TIME STANDARDS

Some of the more common uses of time standards are in connection with

1. Wage incentive plans
2. Plant layout

3. Plant capacity studies
4. Production planning and control
5. Standard costs
6. Budgetary control
7. Cost reduction activities
8. Product design
9. Tool design
10. Top-management controls
11. Equipment selection
12. Bidding for new business
13. Machine loading
14. Effective labor utilization
15. Material-handling studies

Time standards can be established not only for direct labor operations but also for indirect work, such as maintenance and repair, inspection, office and clerical operations, engineering, and management. They can also be set for machinery and equipment, including robots.

## 17.5 COST OF ELECTRIC POWER

by Robert J. Vondrasek and James M. Connolly

REFERENCES: Department of Energy (DOE), "Electric Plant Cost and Power Production Expenses," 1991. Electric Power Research Institute, "Technical Assessment Guide," 1993. Oak Ridge National Laboratory, "CONCEPT-V, A Computer Code for Conceptual Cost Estimates of Steam Electric Power Plants." "Handy-Whitman Index of Public Utility Construction Costs," Whitman, Reardon and Associates. Grant and Ireson, "Principles of Engineering Economy," Ronald Press.

This section is primarily concerned with the economics of electric power production by central station generating plants. The cost of power generated by stationary thermal and hydroelectric plants makes a significant contribution to the price of electric service provided by interconnected and pooled electric utility systems. For a single, isolated plant, often assigned specific industrial or commercial loads, generation costs can comprise a major portion of, or can establish the total price of, power. Generation costs consist of production expenses (fuel plus operating and maintenance expenses) and fixed charges on investment (cost of investment capital, depreciation or amortization, taxes, and insurance).

Interconnected power supply systems must price power to include transmission costs, distribution costs, and commercial expenses. Power price savings are realized by scheduling the installation and operation of a range of plant types to optimize overall generation costs. Generally, efficient plants burning lowest-cost fuels or operating on river water flows that are available the year round are assigned to continuous base-load operation at or near full capacity. Plants bearing low unit-kilowatt investment costs and lower efficiencies are installed to provide peaking capacity. Operation of these units during short daily periods of peak load limits their energy output and thus minimizes characteristic cost penalties associated with their poorer station efficiency or their requirement for higher-priced gas or distillate fuels. Large interconnected utilities may also achieve price benefits by accommodating the staggered installation of large-size units which carry lower unit-kilowatt investments, by supplementing capacity and reserve needs of neighboring systems, and by the daily and seasonal exchange of off-peak, low-incremental-cost energy. Historically, there have been significant regional differences in the price of power. These differences have reflected such factors as availability of hydroelectric energy, the cost of fossil fuels, labor costs, ownership type and investment composition, local tax structure, and the opportunities pooling and coordination provide to exploit the economies of scale.

Cost or price is a basic characteristic of power supply. Along with

relative abundance, reliability, and high quality of service, low prices have encouraged the widespread use of electric energy that has come to be associated with our national way of life. Industrial use of electric energy is particularly heavy in the electroprocess and metallurgical industries. The price of electricity has a significant effect on the end-product cost in these industries. In many manufacturing and process industries, quality of service in terms of voltage regulation, frequency control, and reliability is a major concern. Uninterrupted supply is of crucial importance in many process industries where a power failure may entail material waste or damage to equipment, in addition to loss of production revenue. Because of the flexibility and convenience of electric power, future increases in industrial, residential, and commercial consumption are anticipated despite deregulation, fuel price increases, environmental considerations, and energy conservation efforts.

Various types of power-generating units are owned and operated by industry and private sector investors to provide power (and sometimes steam) to industrial facilities and often sell excess power to the local utility at the avoided cost of incremental power for the utility. Because of the general small size of these units, often dual purpose (power and steam), and lack of reporting information on their economics, this section does not address cogeneration or "dual-purpose" power plants. However, the calculations and information in this section can assist in deciding the advisability of purchasing versus generating electric power.

### CONSTRUCTED PLANT COSTS

A **central station** serving a utility system is designed to meet not only the existing and prospective loads of the system in which it is to function but also the pooling and integration obligations to adjacent systems. Service requirements which establish station size, type, location, and design characteristics ultimately affect cost of delivered power. Selection of plant type and the overall philosophy followed in design must accommodate a combination of objectives which may include high operating efficiency, minimum investment, high reliability and availability, maximum reserve capability margins, rapid load change capability, quick-start capability, or service adaptability as spinning reserve.

For a given plant, the design must account for siting factors such as environmental impacts, subsoil conditions, local meteorology and air quality, quantity and quality of available water supply, access for construction, transmission inertia, fuel delivery and storage, and maintain-



ability. In addition, plant siting and design will be significantly affected by legal restrictions on effluents which may have adverse impacts on the environment. In the case of **nuclear plants**, siting must also consider the proximity of population centers and the size of exclusion areas. Reactor plant design must bear the investments required to control radioactive releases and to provide safeguard systems which protect against accidents. **Fossil-fueled power plants** may be sited adjacent to fuel supplies or in proximity to load centers, thereby increasing transmission costs on the one hand or fuel delivery charges on the other. Depending primarily on climate, plants may be enclosed, semienclosed, or of the outdoor type. Spare auxiliary components can be installed to improve reliability. Increased investments in sophisticated heat cycles and controls, for improved equipment performance, can achieve higher plant efficiencies. **Combustion-turbine combined-cycle plant** outputs are restricted by both increased elevation and high ambient air temperatures. Hydroelectric sites are frequently very distant from load centers and thus require added costs for extensive transmission facilities. Also, **hydroelectric facilities** may provide for flood control, navigation, or recreation as by-products of power production. In such instances, total cost should be properly allocated to the various product elements of the multipurpose project.

An **industrial power plant** provided to meet the requirements of an isolated load entails design considerations and exhibits cost characteristics which differ from those of a central station power plant assigned an integrated role within a connected generating system. Industrial power plants often produce both process steam and electric power. Industrial facilities must often accommodate both base- and peak-load requirements. They may be designed to provide for on-site reserve capacity or spinning reserve capacity. Frequency control and voltage regulation must be viewed as a special problem because of the limited capability of a single plant to meet load changes.

Table 17.5.1 provides typical installed cost data for central station generating plants. The figures represent costs of facilities in place, excluding interest during construction. The cost of land, waste-disposal facilities, fuel in storage, or loaded nuclear fuel is not included. Costs apply to plants completed in 1993. Interest during construction can be estimated by multiplying the simple interest rate per year by the con-

**Table 17.5.1 Typical Investments Costs\* (1993 Price Level)**

Plant description			
Type	Net capacity, MW	Fuel	Total investment cost in \$/net kW
Conventional fossil	500	Coal	1,580
		Oil	1,250
		Gas	930
Advanced light-water reactor	600	Nuclear	1,950
Combustion turbine/combined cycle	300	Gas	590

\* Capital investments exclude costs for the following: initial fuel supply, cost of decommissioning for nuclear plants, main transformers, switchyard, transmission facilities, waste disposal, land and land rights, and interest during construction.

struction period in years and dividing by 2 to reflect the carrying costs on the average commitment of capital toward equipment and labor during construction. Escalation effects for plants to be completed beyond this date may be extrapolated in accordance with anticipated cost trends for labor, material, and equipment. Historical cost trends, by region, as experienced in the power industry, which can be helpful in forecasting future costs, may be determined by use of the figures in Table 17.5.2. Escalation can significantly affect plant costs on future projects, especially in view of the 10- to 12-year engineering and construction periods historically experienced for nuclear facilities and the corresponding 5 to 6 years required for fossil-fueled power plants. In addition to rising equipment, construction labor, and material costs, major factors influencing the upward trend in plant costs include increased investment in environmental control systems, an emphasis on improved quality assurance and plant reliability, and a concern for safety, particularly in the nuclear field.

**Conventional Steam-Electric Plants** Conventional fossil plant investment costs given in Table 17.5.1 are for 500-MW nominal units which are deemed to be representative of future central station fossil units. Costs will vary from those in the table due to equipment arrangement, pollution control systems, foundations, and cooling-water-system

**Table 17.5.2 U.S. Cost Trends of Electric Plant Construction by Region (1973 Index is 100)**

	North Atlantic	South Atlantic	North Central	South Central	Plateau	Pacific
Total: Steam generating plants						
Annual average, Jan. 1, 1983	233	236	234	241	244	251
1984	242	242	242	249	252	259
1985	255	254	255	258	260	269
1986	257	253	256	256	259	269
1987	262	256	260	259	262	272
1988	276	270	275	272	277	287
1989	290	280	286	284	285	297
1990	304	293	299	291	300	311
1991	312	297	306	296	303	317
1992	317	298	307	299	306	323
1993	329	308	318	304	317	333
Total: Hydro generating plants						
Annual average, Jan. 1, 1983	212	216	216	228	228	224
1984	221	219	224	232	235	229
1985	235	232	236	237	247	241
1986	240	231	238	234	247	241
1987	245	232	244	236	252	245
1988	253	238	253	236	256	252
1989	264	246	263	242	264	262
1990	275	255	269	247	267	271
1991	276	256	272	245	271	273
1992	279	248	271	239	267	273
1993	291	259	281	250	278	282

SOURCE: "Handy-Whitman Index of Public Utility Construction Costs," compiled and published by Whitman, Requardt & Associates, 2315 Saint Paul Street, Baltimore, MD 21218.

## 17-34 COST OF ELECTRIC POWER

designs dictated by plant site conditions. The variety of cycle arrangements and steam conditions selected also affects plant capital cost. Plant designers try to economically balance investment and operating costs for each plant. Present-day parameters, in the face of current economics, call for a drum boiler, regenerative reheat cycles at initial steam pressures of 2,400 psig with superheat and reheat temperatures of 1,000°F (539°C). Similar temperature levels are employed for 3,500-psig initial steam pressure supercritical-reheat and double-reheat cycles which require higher investment outlays in exchange for efficiency or heat rate improvements of between 5 and 10 percent. Increased investment costs are also caused by more generous boiler-furnace sizing, and larger fuel- and ash-handling, precipitator, and scrubber facilities required for burning poor quality coals. Investment increments are also required to provide partial enclosure of the turbine building and furnace structure and to fully enclose the boiler by providing extended housing to weather-protect duct work and breeching.

**Nuclear Plants** The construction of nuclear power plant capacity in the United States has been suspended for over a decade. Current construction activities in the nuclear power arena include completing delayed nuclear units and converting existing or partially completed units to fossil fuels. The costs associated with delays and the reengineering required to adapt units to new fuels and thermodynamic cycles is not indicative of the cost associated with committing new nuclear units today. A new generation of smaller light-water reactor nuclear power plants is currently in the design stage. Costs associated with these units, including siting, licensing, and fuel cycle, remain unclear, as they are precommercial. The earliest units will not be offered until the late 1990s. However, they are the basis for nuclear capacity in this section as they are the most likely nuclear units to become commercial in the future. They utilize preengineered designs to reduce construction and licensing time.

In general, light-water reactor nuclear plants require considerably higher investments than do fossil-fueled plants, reflecting the need for leakproof reactor pressure containment structures, radiation shielding, and a host of reactor plant safety-related devices and redundant equipment. Also, light-water reactor plants operate at lower initial steam conditions than do fossil-fueled plants and, because of their poorer turbine cycle efficiency, require larger steam flows and increased equipment sizes at added investment.

Both light-water reactor plants and conventional fossil plants evidence declining unit cost with increasing size. The economy of scale has been demonstrated most strikingly in the nuclear field where orders for units at the 1,200-MW size level had predominated. The utilization of large-size units has been made possible by the interconnection of utility transmission and distribution systems, many of which have grown to levels capable of absorbing large individual units without assuming economic penalties for the reserve equipment required to assure service continuity in the event of unscheduled outages.

**Combustion Turbine/Combined-Cycle Plants** Packaged combined-cycle plants are offered by a number of vendors in the 100- to 600-MW size range. These plants consist of multiple installations of combustion gas turbines arranged to exhaust to waste-heat steam generators which may be equipped for supplementary firing of fuel. Steam produced is supplied to a conventional nonreheat steam turbine cycle. Advantages of combined cycles are lower unit investment costs, efficient thermal performance, increased flexibility (which allows independent operation of the gas-turbine portion of the plant), shorter installation schedules, reduced cooling-water requirements, and the reduction in sulfur oxide and particulate emissions characteristic of gaseous fuels.

**Hydroelectric Plants** Hydroelectric generation offers unique advantages. Fuel, a heavy contributor to thermal plant operating costs, is eliminated. Also, hydro facilities last longer than do other plant types; thus they carry lower depreciation rates. They have lower maintenance and operating expenses, eliminate air and thermal discharges, and because of their relatively simple design, exhibit attractive availability and forced-outage rates. Quick-start capability and rapid response to load change ideally suit hydro turbines to spinning reserve and frequency-control assignments.

The constructed cost of a hydroelectric station is strongly site dependent. Overall costs fluctuate significantly with variations in dam costs, intake and discharge system requirements, pondage required to firm up capacity, and with the cost of relocating facilities within the areas inundated by the impoundments. For a given investment in structures, available head and flow quantity may vary considerably, resulting in a wide range of outputs and unit investment costs. Installed plant costs reported by the Department of Energy for hydro plants include a \$398-per-kilowatt investment for the 140-MW Keowee Plant in South Carolina, completed by Duke Power Company in 1971. The Northfield Mountain Plant of Western Massachusetts Electric Company, completed in 1973, carries an investment cost of \$145/kW owing to a high gross head and smaller pondage volume. Cost prediction for future hydroelectric construction is difficult, particularly in view of the decreasing availability of economical sites and restrictions imposed by concern for the ecological and social consequences of disrupting the natural flow patterns of rivers and streams.

**Pumped-Storage Plants** Pumped-storage plants involve a special application of hydroelectric generation, allowing the use of off-peak energy supplied at incremental charges by low-operating-cost thermal stations to elevate and store water for the daily generation of energy during peak-load hours. Pumped hydro projects must justify the inefficiencies of storage pumping and hydroelectric reconversion of off-peak thermal plant energy by investment cost savings over competing peaking plants. Installation of a pumped hydro station calls for a suitable high head site which minimizes required water storage and upper and lower reservoir areas and an available makeup source to supply the evaporative losses of the closed hydraulic loop. Despite the added complications of installing both pumping and generating units, or of utilizing reversible motor-generator pump-turbines, costs for pumped hydro stations generally fall below those for conventional hydroelectric stations. Lower installed costs are the result of elimination of dams, extensive pondage, and the siting need for appreciable natural water flow. The Department of Energy reports a 1991 installed cost of \$937/kW for the Duke Power Company's 1,065-MW Bad Creek Project. The 1985 Virginia Electric Power Company's Bath County 2101-MW plant carries an investment charge of \$803/kW. Differences in gross head, impoundment, and siting make plant cost comparisons difficult.

**Geothermal Plants** Geothermal generation utilizes the earth's heat by extracting it from steam or hot water found within the earth's crust. Prevalent in geological formations underlying the western United States and the Gulf of Mexico, geothermal energy is predominantly unexploited, but it is receiving increased attention in view of escalating demands on limited worldwide fossil-fuel supplies. Because natural geothermal heat supplants fuel, the atmospheric release of combustion products is eliminated. Nevertheless, noxious gases and chemical residues, usually contained in geothermal steam and hot water, must be treated when geothermal resources are tapped. There is a current lack of significant cost data covering geothermal plants. The major commercial U.S. facility, the Geysers Plant in northern California, began in 1960 as a phased expansion. It uses dry steam at 600°F (316°C). Because boiler and associated fuel-handling facilities are eliminated, investment in these generating plants is considerably less than the cost of comparable fossil-fueled units. However, overall investment chargeable to geothermal facilities includes significant exploration and drilling costs which are site dependent and cannot be accurately predicted without extensive geophysical investigation.

**Environmental Considerations** Environmental protection has become a dominant factor in the siting and design of new power generating stations. Both stack emissions to the atmosphere and thermal discharges to natural water courses must be significantly reduced in order to meet increasingly stringent environmental criteria. In many cases older plants are being required to reduce emission levels to achieve legislated ambient air-quality standards and to control thermal discharges by the use of closed cooling systems to prevent aquatic thermal pollution.

Control of **air pollution** in fossil-fueled power plants includes the reduction of particulates, sulfur oxides, and nitrogen oxides in flue gas

emissions. Particulate collection can be achieved by electrostatic precipitators, baghouse filters, or as part of stack gas scrubbing. Stack gas scrubbing is required for all new coal-fired power plants, regardless of sulfur content of the fuel. Fossil-fueled power plants are believed to be a major contributor to acid rain.

Scrubbers reduce sulfur oxide emissions by contacting flue gas with a sorbate composed of metal (usually sodium, magnesium, or calcium) hydroxides in solution which act as bases to produce sulfate and sulfite precipitates when they contact sulfur oxides in the flue gas. Wet scrubbers contact flue gas with a sorbate in solution. Dry scrubbers evaporate sorbate solution into the gas stream.

Fossil-fueled power plants are required to burn low-sulfur fuels. Restrictions on the use of oil in new power plants and its high cost have virtually eliminated new central station steam power plants designed to utilize oil.

Control of nitrogen oxides  $\text{NO}_x$  is attained primarily through modifications to flame propagation and the combustion processes.

The 1990 amendments to the federal Clean Air Act and proposed restrictions in the new amendment to the federal Water Pollution Act of 1972 (Clean Water Act) will have cost implications that have not been fully documented. Under the influence of the nitrous oxide ( $\text{NO}_x$ ) emission limitations proposed for Phase I and Phase II of the 1990 amendments to the Clean Air Act, steam generator designs will change to incorporate some form of low- $\text{NO}_x$  burners, overfire air dampers, catalyst injection, flue gas recirculation to the burners, and other modifications to meet these new federal standards. New combustion turbine designs are also being developed to meet these new  $\text{NO}_x$  emission regulations.

In order to avoid plant discharges of waste heat to the aquatic environment, evaporative-type closed-cooling cycles are employed in lieu of once-through cooling system designs. Closed-loop cooling systems in current use employ evaporative **cooling towers** or **cooling ponds**. Use of these systems entail investment penalties consisting of net increases in equipment and facilities cost, and penalties incurred by losses in peak capability due to the lower plant efficiency associated with evaporative cooling systems.

More advanced closed-cooling-loop designs anticipate the use of dry and wet-dry cooling towers. These represent possible alternates to conventional evaporative systems where makeup water is in short supply or

where visible vapor plumes or ice formed by vapor discharge present hazards. The penalties for dry-tower cooling are significantly higher than those for conventional evaporative designs. Large, more costly water-to-air heat-transfer surfaces are required, and characteristically higher condensing temperatures result in higher turbine backpressure, severely restricting plant capability.

Although no large-size dry towers are currently in operation in the United States, estimates indicate incremental investment cost penalties for conventional fossil-fueled plants in the range of \$150 to \$200 per kilowatt for mechanical-draft dry cooling towers and of \$300 to \$400 per kilowatt for natural draft, dry cooling designs. Similarly equipped nuclear plants bear dry tower investment cost penalties approximately 40 percent higher than the above. Wet-dry towers show promise for practical application, combining the advantages of both wet and dry tower designs. Wet-dry towers incur added investment penalties for closed heat-transfer surface only to the extent necessary to eliminate visible plume and/or to reduce makeup requirements. Investment cost penalties for wet-dry towers fall between those for wet towers and dry towers.

#### FIXED CHARGES

Costs that are established by the amount of capital investment in plant and which are fixed regardless of production level are termed **fixed charges**. Annual fixed charges are ordinarily expressed as a percentage of investment and include interest or the cost of money, funds applied to amortize investment or to allow for replacement of depreciated plant, and charges covering property taxes and insurance. Additionally, fixed charges may include an interim replacement allowance to cover the replacement cost of plant equipment not expected to last the full life of the plant.

For investor-owned utilities, the **cost of money** employed for utility plant expansion depends upon financial market conditions in general and upon the attitude of investors with regard to a particular utility enterprise or specific project. Funds for investor-owned utility expansion are derived from both the risk capital (equity) and debt capital (bond) markets. Utility bonds command a return of 5 to 7 percent in the current market, while equity capital returns of between 6 and 8 percent are typical. Prevailing return rates for investments in utility plant facili-

Table 17.5.3 Comparison of Interest or Rate of Return and Revenue Requirements for Private and Public Projects

	Investor-owned utility, %	Government-owned utility, %	Industrial-commercial ownership, %
Distribution of investment			
Equity capital (stocks)	40	0	100
Debt capital (bonds)	60	100	0
Total	100	100	100
Rate of return or interest			
On stocks	7.0	0.0	8.0
On bonds	6.0	5.0	0.0
Income subject to federal income tax (FIT)			
Average rate of return	6.4*	5.0	8.0
Deduction for interest	3.6†	5.0	0.0
Net taxable income	2.8	0.0	8.0
Return on equity before 35% FIT			
2.8%/(100 - 35%)	4.3‡		
8.0%/(100 - 35%)			12.3
FIT as percentage of capital			
4.3-2.8%	1.5		
12.3-8.0%			4.3
Summary revenue requirements			
Equity return before FIT	4.3	0.0	12.3
Bond interest	3.6§	5.0	0.0
Total	7.9	5.0	12.3

\* Average return is 7% equity return on 40% of investment plus 6% bond interest on 60% of investment.

† Deduction is 6% bond interest on 60% of investment.

‡ Return on equity equals 7% equity return to stockholders on 40% of investment.

§ Return on debt equals 6% bond interest on 60% of investment.

## 17-36 COST OF ELECTRIC POWER

ties are influenced by the rate-setting practices of public utility regulatory agencies and by supply-and-demand factors in the investment market.

Public utility facilities owned by state and municipal government organizations are generally financed by long-term revenue bonds, most of which qualify for tax-free-income status. Interest rates currently fall between 4 and 6 percent and reflect the tax relief on interest income enjoyed by the bondholders.

Generating facilities are often financed by industrial concerns whose primary business is the production of a manufactured product. In these instances, the annual cost of money invested in power facilities will be established by considering alternate investment of the required funds in manufacturing plant. Inasmuch as returns on equity capital invested in manufacturing industries are usually on the order of 10 to 20 percent, the rate of return for industrial power plants will tend to be set at these higher levels.

Corporate federal taxes are levied on equity capital income. Thus, corporate earnings on equity investment must exceed the return paid the investor by an amount sufficient to cover the tax increment. Current federal tax rates of 35 percent apply. Therefore, revenue requirements for a given return to the investor will amount to slightly less than twice the given rate (see Table 17.5.3).

The amortization of debt capital or the provision for **depreciation** over the physical life of utility plant facilities may be effected by several methods. Straight-line depreciation requiring uniform charges in each year over a predetermined period of useful service is commonly applied because of its simplicity. The percentage method of depreciation assumes a constant percentage decrease in the value of capital investment from its value the previous year, thereby resulting in annual depreciation charges which progressively diminish. The sinking-fund method of economic analysis assumes equal annual payments which, when invested at a given interest rate, will accumulate the capital value of facilities less their salvage value, over a predetermined useful service life. Table 17.5.4 illustrates the representative useful life for alternate utility facilities.

Use may be made of interest tables which show, for any rate of interest and any number of years, the equal annual payment (sinking-fund) rate which will amortize an investment and additionally will yield an annual return on investment equal to the interest rate.

$$\text{Equal annual payment} = \frac{i(1+i)^n}{(1+i)^n - 1}$$

where  $n$  = number of years of life, and  $i$  = interest rate or rate of return.

Property taxes and property insurance premiums are normally established as a function of plant investment and thus are properly included as fixed charges. Property taxes vary with the location of installed facilities and with the rates levied by the various governmental authorities having jurisdiction. In general, public power authorities will be free of taxes, although public enterprises often render payments to government in lieu of taxes. Annual property tax rates for private enterprise will amount to perhaps 2 to 4 percent of investment, while property insur-

**Table 17.5.4 Representative Useful Life of Alternate Utility Facilities**

Facility	Representative useful service life, years
Steam-electric generating plant	30
Hydroelectric plant	50
Combustion turbine-combined cycle	30
Nuclear plant	30
Transmission and distribution plant	40

ance may account for annual costs of between 0.3 and 0.5 percent.

A representative makeup of fixed charges on investment in a conventional steam-electric station having a useful service life of 30 years is shown in various classes of ownership in Table 17.5.5.

### OPERATING EXPENSES

**Fossil Fuels** Currently, fossil fuels contribute approximately three-fourths of the primary energy consumed by the United States in the production of electric energy. Generating station demands for fossil fuels, particularly coal, are continuing to increase as the electric utility and industrial power markets grow. Price comparisons of fossil fuel are generally made on the basis of delivered cost per million Btu. This cost includes mine-mouth or well-head price, plus the cost of delivery by pipeline or carrier. Price comparisons must recognize that solid and, to a lesser extent, liquid fuels require plant investments and operating expenditures for fuel receipt, storage, handling and processing facilities, and for ash collection and removal. High transportation cost contributions on a Btu basis will be incurred by high-moisture and ash-content coals with low heating values. It is, therefore, advantageous to fire lignite and subbituminous coals at mine-mouth generating plants.

**Coal** represents our most abundant indigenous energy resource, with enough economically recoverable supplies at current use rates to last well into the next century. About half of the recoverable coal reserves have a sulfur content above 1 percent and are considered high-sulfur coal. Low-sulfur coals are found chiefly in the low-load areas of the mountainous West, and delivered cost at the major markets east of the Mississippi include high transportation charges. Increasingly, coal production is bearing the cost of more rigid enforcement of stringent mine safety regulations, and the charges associated with strip-mine land restoration. Delivered price depends upon transportation economies as may be affected by barging, unit train haulage, or pumping in slurry pipelines. Delivered price levels for coal fuel vary with plant location. Plants conveniently located with respect to eastern coal reserves report delivered-coal prices in the general range of \$1.25 to \$2.00 per million Btu, depending upon sulfur and ash content. Low-sulfur western subbituminous coals have delivered prices of between \$1.00 to \$1.75 per million Btu.

The domestic supply of **petroleum** is now outstripped by nationwide demand. The United States has become dependent on overseas sources

**Table 17.5.5 Derivation of Fixed-Charge Rate for Conventional Fossil-Fueled Steam-Electric Plant with 30-Year Economic Life**

	Investor-owned utility, %	Government-owned utility, %	Industrial-commercial ownership, %
Rate of return or interest*	6.4	5.0	8.0
Amortization or depreciation†	1.2	1.5	0.9
Federal income tax	1.5	0.0	4.3
Local taxes (or payment in lieu of taxes)	2.0	2.0	2.0
Insurance	0.3	0.3	0.3
Total	11.4‡	8.8	15.5

\* Interest or return rate is listed in Table 17.5.3.

† Sinking-fund amortization or depreciation rate (at given rate of return or interest), which when added to the rate of return or interest equals the capital recovery factor.

‡ Assuming initial plant investment of \$930/kW and 7,500 h/year operation at full load, the annual fixed charges in mills per kilowatthour will be  $930 \times 0.114 \times 1,000/7,500 = 14$  mills/kWh.

**Table 17.5.6 Operating Expense for Fuel for Representative Heat Rates and Fuel Prices**

	Nominal size, MW	Typical heat rate, Btu/kWh	Fuel price, ¢/MBtu	Fuel cost, mills/kWh
Conventional coal fired	500	9,800	200	19.6
Advanced light-water reactor	600	10,700	60	6.4
Combustion turbine/combined cycle	300	8,000	220	17.6

NOTE: Operating fuel cost, mills/kWh = (Btu/kWh) × (¢/Btu) × 10<sup>-5</sup>.

to meet growing energy demands. The consequences of this trend are a continued unfavorable balance of payments and dependence on foreign oil supplies from politically unstable areas in the Middle East and North Africa. Residual and distillate oil prices have risen because of short supply and pressure by the major oil producers on worldwide market price levels. Blends of low-sulfur oils delivered during 1993 to generating plants along the eastern seaboard were priced upward from \$3.50 per million Btu to as high as \$4.50 per million Btu for the 0.3 percent sulfur fuel required for firing in some metropolitan areas. During this same period distillate oil commanded a nationwide price ranging from approximately \$4.00 to \$5.00 per million Btu.

Consumption of **natural gas** as a power fuel is increasing because it is clean burning, convenient to handle, and generally requires smaller and cheaper furnaces. Historically, its limited supply made it best-suited for consumption by residential and commercial users and meeting industrial process needs. Present-day power plant use of natural gas is on the rise, especially in plants located in the gas-producing areas of the south central and western states. Gas fuel prices for 1993 ranged from \$2.00 to \$3.50 per million Btu. Price levels of natural gas, severely regulated in the past by government controls imposed at the well, have been falling sharply in response to current supply-and-demand factors and deregulation.

**Nuclear Fuel** Reactor plant fuel costs present a special case. Actually, the initial core loading which will support operation of a nuclear plant over its early years of life requires a single purchase prior to commissioning of the plant. For comparison with fossil-fuel prices, therefore, nuclear-fuel cycle costs, including first-core investment, periodic charges for reload fuel, and spent-fuel shipment and processing costs, are ordinarily extrapolated at assigned load factors over the life of the plant and are converted to an economic equivalent expressed in dollars per million Btu of released fission heat. Nuclear-fuel costs are not only influenced by ore prices and by fuel fabrication and processing costs, they are also sensitive to investment and uranium-enrichment costs. Future costs are subject to inflationary pressures and cost-saving technology changes such as extended burn-up cycles. Charges of 50 to 70 cents per million Btu are representative of the leveled fuel prices for nuclear plants.

**Operating Costs of Fuel** Fuel price contributions to energy-generation costs will reflect start-up and furnace-banking losses and will depend upon plant efficiencies which, at low loads, show considerable departure from the best-point performance achieved at or near full unit loadings. These factors significantly affect the operating expenses of load-following utility system units as well as plants assigned fluctuating demands in manufacturing or industrial service. As an example, calculated performance for a nominal 500-MW, 2,400-psig coal-fired regenerative reheat steam unit shows a best-point heat rate of 9,800 Btu/net kWh at rated output. Load reduction yields heat rates of 10,500 and 12,400 Btu/kWh at loadings of 250 MW and 125 MW, respectively. Typical operating-expense ranges for given fuel prices and estimated full-load heat rates may be determined directly where continuous operation at or near unit rating is assumed (Table 17.5.6).

**Operating Labor and Maintenance** In addition to fuel costs, operating expenses include labor costs for plant operation and maintenance, plus charges for operating supplies and maintenance materials, general administrative expenses, and other costs incidental to normal plant operation. Operating labor and maintenance costs vary considerably with unit size, operating regimen, plant-design conditions, type of facility, and the local labor market. Representative figures appear in Table

17.5.7. Nuclear liability insurance costs are included under reactor plant operating expenses. They finance a program of government indemnity, coupled with private insurance, for public damage that could arise from a nuclear incident.

**Environmental Controls** Systems and equipment required for air and water pollution abatement generally carry increased fuel and maintenance labor and materials costs. Reductions in plant output resulting from the higher condensing pressures associated with cooling-tower operation or the added auxiliary power for stack gas clean-up systems lower plant efficiency and increase fuel consumption.

#### OVERALL GENERATION COSTS

The total cost of power generation may now be estimated by reference to the preceding material assuming type of ownership, capital structure, plant type, fuel, and loading regimen. Table 17.5.8 comprises an illustrative tabulation of the factors determining the overall generation cost of an investor-owned nuclear generating facility.

It should be noted that capacity factor, or the ratio of average-actual to peak-capable load carried by a given generating facility, will have a significant effect on generation expenses. In addition to the effects of part-load operation on fuel costs as previously discussed, capacity factor will determine the plant generation which will support fixed charges. High-capacity-factor operation will spread fixed charges over a large number of kilowatt-hours of output, thereby reducing unit generation costs. During its initial life, a thermal plant is usually operated at high-capacity factor. As inevitable obsolescence brings newer and more efficient equipment into service, a unit's baseload position on the utility system load duration curve is relinquished, and capacity factor tends to drop. This decline in capacity factor must be acknowledged in estimating output and generation costs over the life of a given facility.

Most modern electric utilities incorporate computerized systems designed to economically dispatch power generated at each production plant feeding the load. Individual generating-unit loads are assigned in a manner that can be demonstrated to result in minimum overall cost; i.e., at each system power level, load is shared between units so that all operate at the same incremental production cost. Telemetered data reflecting system load and generation is transmitted to central dispatch computers by multiplexing via power line carrier, microwave, or telephone lines. The communication schemes include channels for transmitting load adjustment commands developed by the computer to on-line generating units. Loading instructions account for the unit production efficiencies and transmission losses associated with each dispatch assignment.

**Table 17.5.7 Representative Operating and Maintenance Costs (1993 Price Level)**

Type of plant	Nominal size, MW	Fuel	Operating and maintenance costs, mills/kWh
Conventional fossil	500	Coal	6–8
Advanced light-water reactor	600	Nuclear	5–9
Combustion turbine/combined cycle	300	Gas	6–10
Conventional hydro	300	—	5–7

NOTE: Unit kilowatt-hour costs include labor, maintenance materials, operating supplies, and incidental expenses. Costs shown assume base-load operation.

## 17-38 COST OF ELECTRIC POWER

**Table 17.5.8 Total Cost of Generating Power**  
(Plant type: 500-MW conventional fossil; plant net heat rate: 9,800 Btu/kWh)

	Generating costs, mills/kWh
Coal fuel @ \$2.00/mBtu	19.6
Operating and maintenance	7.0
Fixed charges @ 11.4% per annum	24.0
Total operating costs	50.6

NOTES: Fixed charges are based on assumed initial plant investment of 1,580/kW and 7,500 h/year of operation. Values shown are typical and could vary significantly for individual plants.

### TRANSMISSION COSTS

Because of a growing scarcity of urban sites and increasing emphasis on environmental protection and nuclear safety, it has become more and more difficult to site major power stations near centers of load. As a consequence, added cost of transmission along with attendant resistive power losses add significantly to the overall cost of service. Because of the distances involved, these costs are generally greatest for nuclear facilities, mine-mouth stations, and hydroelectric plants where remoteness or remote resources strongly govern siting. Transmission plant investment also reflects a trend toward interconnection of neighboring utilities. Designed to improve service reliability by the pooling of reserves and to effect savings by capacity and energy interchanges, such interties must carry substantial ratings so that emergency power transfers can be accommodated without exceeding system stability limits. Costs for major overhead transmission ties (1,000 MVA and up) are estimated to range between \$300,000 and \$700,000 per circuit mile depending on terrain and voltage level. Investments are also sensitive to factors of climate and proximity to urban areas that can increase right-of-way costs significantly. Where underground transmission is elected, installed investment costs can be as much as 10 times the cost of overhead lines.

The choice of **transmission voltage** level and whether ac or dc is used for bulk power transfer depends on the amount of power transmitted, the transmission distance involved, and at each voltage level, the cost of line and substation equipment. Voltages generally employed are 230, 345, 500, and 765 kV ac and 5000+ kV dc. Where long distances on the order of 400 mi (650 km) or more are encountered, dc transmission becomes economically attractive. For shorter lines, however, savings in fewer conductors and lighter transmission towers are nullified by the high cost of dc-ac conversion equipment at both line terminals.

### POWER PRICES

The price of power delivered by a utility system must account for the production costs at each of its generating stations. As previously noted, these costs depend upon labor rates, fuel prices, and material charges. They reflect investment levels in generating plant and the fixed-charge rates established by funding patterns, type of ownership, and expected equipment service life. Overall system production costs are affected by the investment requirements of specific mixes of generating equipment types, and by the manner in which load is shared by units, i.e., how production is allocated between highly efficient base-load stations and the less-efficient peaking equipment which normally runs for only a few hours each day. Also, important cost reductions are achieved in hydro systems by controlling natural and stored water flows to allow optimized sizing and scheduling of hydroelectric output, thereby reducing needs for thermal peaking capacity and decreasing the generation requirements of high fuel cost fossil plants.

Power prices cover the investment charges, maintenance costs, and capacity and energy losses chargeable to the transmission and distribution plant. They also include the administrative costs incurred to maintain corporate enterprise and the commercial expense of metering and billing.

Generally, power prices must provide a return to cover the average cost of power production throughout a given system. Rate schedules and supply contracts, however, are drawn to reflect the reduced cost of off-peak energy produced by available generating units during periods of low system load. Additionally, prices for high load factor service often recognize the cost reductions effected by spreading fixed charges over increased units of energy output. Large blocks of capacity and energy supplied for industrial use are often priced by establishing an annual charge for capacity which equals the fixed charges on investment in committed generation and transmission plant, plus charges for energy representing the sum of the variable kilowatt-hour production costs for fuel, maintenance, and operation.

Historically, utilities have applied rate schedules which promote consumption by applying progressively lower rates to blocks of increased energy usage. Rationale for such pricing is the savings that load growth can realize through economies of scale, as well as the improved utilization of existing utility plant. However, regulatory pressure, reflecting a policy of minimizing the industry's impact on the environment and the critical need to conserve high-cost imported fuel, has favored a marginal cost-pricing system more nearly reflecting the actual cost of production and transmission of a particular user's supply of power. Rate setting under this conservationist approach calls for flat, rather than reduced, rates as usage increases and for high unit energy charges during peak-load periods.

Facilities designed for the **dual-purposes production of power and process steam** permit investment savings, principally in steam-generation plants, which result in combined production charges falling below the total cost of separate, single-purpose production of power and of steam. Such savings can permit proportionate decreases in the prices ordinarily charged for separate single-purpose production of each of the products, or they may be assigned in total to reduce the price of one or the other by-product. This latter option is often exercised in the case of dual-purpose water product plants arranged for seawater flash evaporation using power-turbine extraction as a process steam source. Where severe shortages of fresh water exist, social considerations favor the total assignment of dual-purpose savings to the water product. Thus, minimal prices for desalted product water are achieved, while dual-purpose power is marketed at prices competing with single-purpose power generation costs. Similarly, assignment of the total savings of dual-purpose power and process steam production to the power product may justify on-site industrial plant power generation in preference to outside purchases of higher-priced utility system power supplies.

**Table 17.5.9 Average Revenue per Kilowatt-Hour Sold to Customers for the Total U.S. Electric Utility Industry**  
(Cents per kilowatt-hour)

Year	Residential	Commercial	Industrial	All
1973	2.35	2.30	1.17	1.86
1974	2.83	2.85	1.55	2.30
1975	3.21	3.23	1.92	2.70
1976	3.45	3.46	2.07	2.89
1977	3.78	3.84	2.33	3.21
1978	4.03	4.10	2.59	3.46
1979	4.43	4.50	2.91	3.82
1980	5.12	5.22	3.44	4.49
1981	5.86	6.00	4.03	5.16
1982	6.44	6.61	4.66	5.79
1983	6.83	6.80	4.68	6.00
1984	7.17	7.14	4.88	6.27
1985	7.39	7.27	5.04	6.47
1986	7.43	7.22	4.99	6.47
1987	7.45	7.10	4.82	6.39
1988	7.49	7.04	4.71	6.36
1989	7.65	7.20	4.79	6.47
1990	7.83	7.33	4.81	6.57
1991	8.05	7.54	4.89	6.76
1992	8.17	7.62	4.89	6.81

SOURCE: Edison Electric Institute.

Where hydro facilities supply power in combination with irrigation, flood control, navigation, or recreational benefits, power costs are largely sensitive to the allocation of investment charges against each of the multipurpose project functions. Should generation be treated as a by-product, power prices can be reduced drastically to reflect equipment operating expenses and the limited fixed charges covering investment in only the generating plant itself.

Cheap fuel, advances in design, the economies of scale, and the economic application of alternate generating unit types produced downward trends in the price of electric service in the 1960s. In the 1970s

these trends were reversed by inflationary effects on plant costs, high interest rates, and the increased prices commanded by fossil and nuclear fuels (see Table 17.5.9). A dwindling number of favorable plant sites, licensing delays, and the added costs of environmental impact controls combined to cause further upward pressure on power prices in the 1980s. However, falling interest rates and fuel prices began to slow the rate of increase in the cost of electric power. These stabilizing influences have continued into the 1990s, tempered by stricter environmental regulation costs. Increases in electric rates are expected into the foreseeable future.

## 17.6 HUMAN FACTORS AND ERGONOMICS

by Ezra S. Krendel

REFERENCES: McRuer, Pilot-Induced Oscillations and Human Dynamic Behavior, *NASA CR-4683*, July 1995. McRuer, Human Dynamics in Man-Machine Systems, *Automatica*, **16**, 1980. McRuer and Krendel, Mathematical Models of Human Pilot Behavior, *AGARDograph no. 188*, 1974. Krendel and McRuer, "A Servomechanism Approach to Skill Development," *J. Franklin Inst.*, **269**, 1960. Wright, "Factors Affecting the Cost of Airplanes," *J. Aeronautical Sciences*, **3**, 1936. Reason, "Human Error," Cambridge University Press. Konz, "Work Design: Industrial Ergonomics," 3d ed., Publishing Horizons. Atkinson, Herrnstein, Lindzey, and Luce (eds.), "Stevens' Handbook of Experimental Psychology," 2d ed., vols. I and II, Wiley. Salvendy (ed.), "Handbook of Human Factors," Wiley. Boff, Kaufman, and Thomas (eds.), "Handbook of Perception and Human Performance," vols. I and II, Wiley. Swain and Guttman, *Handbook of human reliability analysis with emphasis on nuclear power applications*, NUREG/CR-2744, U.S. NRC, 1983.

### SCOPE

The goal of human factors and ergonomics is to improve the performance, reliability, and efficiency of systems in which humans operate in concert with machines, man/machine/systems (MMSs). This discipline developed rapidly during and after World War II. The life-or-death stakes and the advances in military technology made even minor improvements in military systems highly desirable and major improvements essential. In subsequent years the risks of accidents and the complexity and costs of military hardware, manned space exploration, nuclear power plants, vehicular control, and civil air transportation were behind the continued development of human factors/ergonomics as an engineering discipline. Commercial applications in product design, industrial process control, quality control, health care technology, computers, and office design have expanded this development. Human factors engineering and ergonomics draw on or interact with the theories and data of many diverse disciplines: psychology, physiology, and applied physical anthropology; aeronautical, electrical, industrial, mechanical, and systems engineering; and computer and cognitive sciences.

Humans operate as sensors, information processors, actuators, and decision makers. The models used to describe these operations are determined by the MMS. For an important and extensively studied family of MMSs—the manual control of air, space, ground, or sea vehicles—the range and variability of allowable manual control is constrained, particularly when the system is operating near its stability limits. The repertory of human control dynamics behavior modes, which demonstrates the adaptive skills the operator applies to reorganizing inputs so as to maintain system performance, can then be described with the same mathematics as the inanimate system components. In applications which emphasize signal detection and decision making (as in monitoring or visual search) or estimate human reliability, performance is best described probabilistically. When the human is a significant source of energy (as in heavy industry or intense athletic activities), power output decrements over time are the main interest.

What follows presents hints at this mass of information, with some useful empirical rules, and concludes with an example of closed-loop compensatory control, the first stage in the repertory of human dynamics behavior modes.

### PSYCHOMOTOR BEHAVIOR

Psychomotor behavior is the activity of receiving sensory input signals and interpreting and physically responding to them. Humans can receive inputs by vision, hearing, smell, and the cutaneous senses which respond to temperature, mechanical energy, or electrical energy. Kinesthesia and the vestibular sense inform about location and position. Vision followed by hearing are the most important senses for transmitting signals carrying complex information for decisions and for control of MMSs. Signals for warning or alerting need not be complex and can be transmitted by one or a combination of the sensory channels. The choice is determined by the situation and the task being performed by the person or persons to be warned rather than by differences in modalities reaction times.

The sense dominating psychomotor behavior, vision, receives light signals by either of two different retinal receptors, cones for photopic and rods for scotopic vision, which convert optical images to signals sent to the brain. Daylight color vision and detailed visual acuity are photopic. Scotopic vision is black and white with shades of gray. Cones are concentrated in the fovea, a central area whose visual angle subtends 30 minutes of arc, and are found in very small numbers elsewhere on the retina. The distribution of rods extends to the periphery of the retina but not to the fovea. Their concentration is greatest at about 20° from the fovea.

After adaptation in the dark for 5 min, the cones are at their maximum sensitivity to low light levels below which color vision is lost. After 30 min in the dark, the rods reach their maximum sensitivity to low light levels. Adapting from a dark environment to a light one takes about a minute; time to readapt to the dark can be brief if the time has been spent under red light. Red light stimulates cones, but not rods, enabling the rods to retain their previous adaptation to a low light level.

Perception of objects and events results from sensory inputs and their interpretation by the brain. Deliberately devised size and distance illusions trick the brain by manipulating expected cues for size, distance, and perspective. Unintended illusions or misleading perceptions can arise when the brain relies on inappropriate sensations or expectations. The process of perception of the size and distance of an object begins when light from the object passes through the observer's pupil and lens. An image is focused on the retina by the action of the ciliary muscles, which can change the accommodation of the lens. Estimates of an object's apparent distance are influenced by this muscle action, by the visual cues leading to the object, and by the expectations of the viewer for the size of the object. These cues may be inadequate or they may be inconsistent with one another and as a consequence create a perception

## 17-40 HUMAN FACTORS AND ERGONOMICS

of distance which differs from reality. As an example, the vision of the driver of an automobile may be accommodated to the dashboard displays at a distance focus of 0.5 m. Refocusing on an unexpected distant object may take as long as 0.4 s. The object may be unfamiliar and visual cues obscured by darkness or fog. Even a briefly held misperception of object size or distance risks an error and an accident.

Complex psychomotor behavior may be constructed by incrementally aggregating a sequence of elemental discrete actions, by continuous closed-loop control, by complex open-loop activities, and by combinations of the above. Choice reaction time (RT) is an elemental discrete action whose duration is a function of the number of alternative choices and their probabilities. An example is a horizontal line of  $n$  signal light bulbs, below each of which is a key to be struck as quickly as possible when the corresponding bulb lights up. If  $n = 1$ , RT would be about 200 ms for a practiced alert operator. As  $n$  increases, the operator's uncertainty,  $H = \log_2(n + 1)$ , which allows for no response, increases, and RT increases proportionally. This is the *Hick-Hyman law*:

$$RT = a + bH \quad (17.6.1)$$

In information theory  $H$  is a measure of uncertainty or entropy in bits.  $H$  can be calculated whether the stimuli are equally likely or whether their probabilities of occurrence differ. The upper limit of  $H$  is slightly more than 3 bits. For the example given  $a$  is about 200 ms,  $b$  is about 150 ms, and  $H$  ranges from 0 to a little over 3 bits. An application is the calculation of RT differences among MMS designs for which values of  $a$  are likely to be similar.

The movement time (MT) for rapid discrete or repetitive actions, usually by the hands, is proportional to the difficulty of the task. *Fitts' law* defines an index of difficulty  $I_D$  in terms of target width  $W$  and movement amplitude  $A$ :

$$I_D = \log_2(2A/W) \quad (17.6.2)$$

$$MT = c + dI_D \quad (17.6.3)$$

The form of Eq. (17.6.3) is an empirical description of data from a wide range of rapid movements as in operating a key pad or in sorting items into bins. In applications,  $d$  is about 100 ms and  $c$ , which depends on the movement geometry, is approximately 200 ms. Estimates of MT provide comparisons among operating procedures.

The equations for RT and MT imply a stable level of skilled performance. The learning curves for psychomotor skills which depend on negative feedback are exponential functions of time. For other psychomotor tasks, skill learning follows a power function whose form is the same as the empirical learning curve developed by Wright to predict the unit cost of producing aircraft, and is

$$y = a x^{-b} \quad (17.6.4)$$

where  $y$  is the number of direct labor hours to produce the  $x$ th unit,  $a$  is the hours to produce the first unit, and  $b$  is the rate that labor hours decreases with cumulative output. For learning a psychomotor skill,  $a$  ranges from 0.2 to 0.6. For production  $a$  ranges from 0.1 to 0.5 with an expected value across industries of about 0.3. The empirical power function when fitted with a straight line on log-log coordinates smooths variability and simplifies quantifying production improvements over time. Each doubling of cumulative output results in a reduction of unit cost by a fixed percentage of its beginning cost. A progress ratio  $p$  of 80 percent means that after each doubling of the cumulative unit output, the unit cost is 80 percent of its value before doubling.

### SKILLS AND ERRORS

The dynamics of psychomotor skill development and its negative, poor performance and the emergence of errors, is a pervasive consideration in MMS design. The highest level of psychomotor skill is attained by a process of successive organization of perceptions (SOP), whereby operators fully familiar with the dynamics of the machine under their control and the appropriate responses to the input signals can reorganize the system, adapt their behavior to create a repertory of special responses,

and then select from this repertory the appropriate response for system performance. In closed-loop control this response may be anticipatory and compensate for inherent human control lags. In an open-loop mode the response may be programmed, as in executing the sequential actions in preparing to stop a car on approaching a red light. Skilled performance can degrade precipitously if inappropriate cues contaminate the perceptual organization or cause it to regress; training in cue recognition is essential.

The level of skilled performance achieved and its variability is affected by individual abilities, training, motivation, attention, workload, work scheduling, the social environment of the activity, and impairment due to substance abuse, stressors, or fatigue. By adhering to human factors findings in the selection and positioning of information displays, controls, monitors, keyboards, seating, and accommodating the physical dimensions of the operator, the designer can make sustained desirable performance more likely, and thwarted or unintended responses less likely. Unintended responses such as misreading a display or inadvertently reaching for the wrong switch result in errors characterized as *slips*. The potential for catastrophic accidents in the operation of nuclear power plants, chemical plants, aircraft, and oil tankers emphasizes the need to design against such slips and to be able to estimate the reliability of both the MMS tasks and the total system. By ascribing human error probabilities to slips and other deteriorations in performance and developing detailed event trees for the many complex MMS tasks, Swain and Guttman were able to estimate human reliability in much the same way that the reliability of inanimate devices has been estimated. Although their numerical reliability estimates cannot always be precise, they enable comparisons to be made of the MMS's reliability under alternative physical configurations, training disciplines, and institutional policies.

A different type of error in behavior arises from *mistakes* in the human's thought processes. Mistakes are similar to errors arising from perceptual illusions in their inappropriate reliance on expectations and experiences. When the error is a mistake, the human operator has misinterpreted the situation, and reliability estimates are not feasible. The mental processes leading to mistakes have been developed from detailed reconstructions of the human actor's thought processes and behavior in accidents and near accidents. The basic sources are accident reports, anecdotes, interviews with survivors, and skilled introspection on the part of the analyst. If the mistake is made under time pressure, it is difficult for the operator to reexamine the situation, sort out misconceptions, and examine options in a deliberate manner. Ergonomic design can make mistakes less likely and recovery more likely by reorganizing the information displays. A more direct approach to lessening the incidence of mistaken intentions is to design redundancy into the MMSs and to develop training and personnel selection procedures which emphasize the search for options and discourage perseverative mistaken thought processes.

### MANUAL CONTROL

Compensatory closed-loop tracking is that control mode in which the human responds to the error signal alone. Progressively more effective modes attained via SOP enable the human to respond to the input and output signals as well, to preview the input, and finally to respond intermittently open-loop in a dual-mode configuration. Instabilities and oscillations in the compensatory closed-loop task can occur if the open-loop gain is too high. A human operator who has regressed to the compensatory mode may inadvertently generate excessive gain and destabilize the system. Pilot-induced oscillations are undesirable, occasionally catastrophic, sustained aircraft oscillations which occur because the pilot insists on maintaining closed-loop control of what would otherwise be a stable aircraft.

Figure 17.6.1 is a simplified block diagram for compensatory closed-loop control. If the controlled element is an automobile or an aircraft, the dynamics can be approximated by first- and second-order systems in the region of human control. The human operator is a quasi-linear element. For such an element the response to a given input is divided into two parts: describing-function components which correspond to the re-



sponse of the equivalent linear elements driven by that input, and a "remnant" component which represents the difference between the response of the actual system and a system composed of equivalent linear elements. The describing function and remnant depend explicitly on the task variables (which are inputs, disturbances, and controlled-element dynamics) and on operator-centered environmental and procedural variables. The effects of these variables have been integrated into a set of rules for applying and adjusting human-operator describing functions. These rules are fairly simple when the plant dynamics either are or can be approximated by first- or second-order dynamic systems. The following conditions must apply before using these rules:

1. The forcing functions which act as inputs to the MMS are unpredictable, have low bandwidth (below 1 Hz), and are continuous waveforms.
2. The controlled element is a low-order system or can be so approximated and has no highly resonant modes over the input bandwidth.
3. The display and controls are reasonably well scaled and smooth so as to minimize the effects of thresholds, detents, and friction.
4. The other task demands are sufficiently light to permit the operator to devote the majority of his or her attention to minimizing the displayed error.

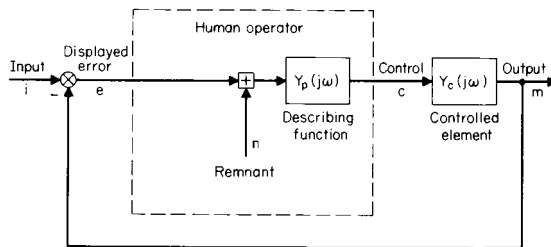

Fig. 17.6.1 Simplified block diagram for manual control.

#### McRUE'S RULE

Under these conditions (which are commonly met in most operational control tasks), theory, experiments, and practice have shown that the human operator attempts to compensate for the dynamics of the controlled element so that the open-loop characteristics of the human-

chine system acts like an integrator in series with a time delay in the frequency range most critical to system stability and performance. The open loop for Fig. 17.6.1 is  $Y_p(j\omega)Y_c(j\omega)$ . This behavior, most noticeable in the region of open-loop crossover—e.g., where the open-loop gain is unity—is known as **McRuer's rule** and is summarized in Eq. (17.6.5) where  $\tau$  is the effective time delay.

$$Y_p(j\omega)Y_c(j\omega) = \frac{\omega_c e^{-j\omega\tau}}{j\omega} \quad (17.6.5)$$

#### CROSSOVER FREQUENCY

Two examples where the conditions on controlled-element dynamics readily obtain are for automobile heading control at low to moderate speeds where  $Y_c(j\omega) = K_c/j\omega$ , and for attitude control of a spacecraft with damper off where  $Y_c(j\omega) = K_c/(j\omega)^2$ . The term  $\omega_c$ , is the crossover frequency which is defined at the condition where the open-loop magnitude is unity. This frequency is important in the design of closed-loop control systems because many of the basic qualities of feedback systems relate to it. Thus, in the range of input frequencies from very low up to and including the crossover frequency  $\omega_c$ , the output of the closed-loop system ( $m$  in Fig. 17.6.1) follows the system input ( $i$  in Fig. 17.6.1) closely, and the system error ( $e$  in Fig. 17.6.1) is reduced. At increasingly higher frequencies beyond crossover, these properties are lost as the error increases and the input and output of the system are no longer similar. For desirable closed-loop performance, the crossover frequency must exceed the largest frequency in the input or in the disturbances to the system for which there is appreciable power. McRuer's rule also permits simple calculations of system stability from the two-parameter model in the vicinity of crossover. Phase margin,  $\phi_M = (\pi/2) - \omega_c\tau$ . System performance can be estimated by use of this model. The conditions are that the input can be approximated by a nearly flat spectrum of bandwidth  $\omega_i$  and variance  $\sigma_i^2$ , and that  $\omega_i/\omega_c$  be somewhat less than unity. Under these conditions, the relative mean-square error coherent with the input can be expressed as

$$\frac{\bar{e}_i^2}{\sigma_i^2} = \frac{(\omega_i/\omega_c)^2}{3} \quad (17.6.6)$$

The total mean-square error will be somewhat larger since it includes an operator-induced remnant as well.

## 17.7 AUTOMATIC MANUFACTURING

by Vincent M. Altamuro

The production of many products involves both **fabrication** and **assembly** activities. Fabrication is the making of the component piece parts that are later assembled into the final product. Fabrication methods include casting, molding, forging, forming, stamping, and machining. Assembly may be manual or automatic. Automatic manufacturing can range from **semiautomatic** to **fully automatic**, depending on the number of human operations required. Automatic manufacturing installations may also be called **fixed** and **flexible** according to how easily they can be altered to make product variations. These several available modes allow the creation of a mode that draws on all of them—the **autofacturing** mode, that combination of the manual and the specific types of automatic operations which best achieves the quality, operational, and economic objectives sought.

The selection of assembly mode must be consistent with the design of the product, the personnel skills, the equipment available, and other factors. Manual assembly is suitable for low volume output and relatively short production runs with high product-to-product variations.

Fixed automatic assembly is suitable for high-speed, high-volume production of uniform products. Also called *hard*, *dedicated*, or *conventional* automation, it can produce low-unit-cost items of uniformly high quality once its machinery is perfected and until a product variation is wanted. If a product's assembly cost is the sum of its *setup cost* (the cost of getting everything ready to make it) and its *run cost* (the cost of making it), then manual assembly has a relatively low setup cost but a high run cost, while fixed automatic assembly has the reverse. Flexible automatic assembly is suitable for midrange-volume production with variations in product specifications. Also called *soft* or *programmable* automation, it uses robots and other computer-based equipment that are more easily movable and adjustable so as to reduce setup costs and still enjoy low run costs. It fits between fully manual and fully fixed automatic assembly, as shown in Fig. 17.7.1.

**Autofacturing** is a production system that is comprised primarily of automated equipment which is configured as several integrated subsystems, using one common database and computer controls to make, test,

## 17-42 AUTOMATIC MANUFACTURING

and transport specifically designed products at high and uniform quality levels meeting flexible specifications with a minimum of human effort. There are many levels of autofacturing from individual cells, or *islands*, all the way up to a complete and integrated system. Most situations are somewhere in between, but progressing toward a total system.

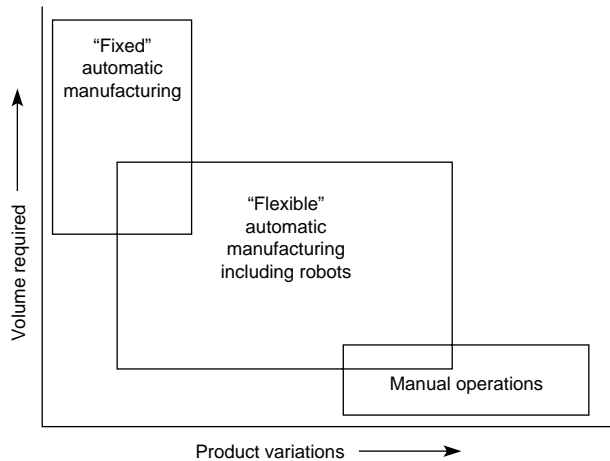

Fig. 17.7.1 The most appropriate assembly mode, as a function of output volume and variations.

Autofacturing is a subset of the overall field of automation. It refers to automated manufacturing activities as distinguished from the many other things called automation, such as data processing, office automation, electronic funds transfers, automated banking, central station telephone operations, airline ticket reservations, and the like.

An autofacturing system is composed of several integrated subsystems. Also, along with other systems such as marketing and distribution systems, general accounting and cost accounting systems, management information systems (MISs), and others, it is a subsystem of the corporation's overall operating system. All subsystems should be interconnected, complementary, in balance, and integrated into one total system. Some of the prerequisites and subsystems of an autofacturing system are listed and described below.

### Design for Assembly

After management decisions regarding organization, staffing, and product characteristics have been made, the first engineering step is to design the product for ease and economy of assembly. In designing a product, decisions must be made regarding which portions of it should be assembled by people, hard automation, and programmable devices, since the shape and features of its parts will often be different for each mode.

Human assemblers, for example, have the advantage of three-dimensional vision, color sensitivity, two hands, eye-hand coordination, the facility to jiggle parts together, the ability to back off when things do not go together as they should and look for the reason rather than force them, the ability to pick out patterns which are varied or complex, etc. However, they cannot work in dangerous environments, apply large or exact forces, perform with precision consistently cycle after cycle, or handle very large, very small, or very fragile items, etc.

Hard automation requires the input of a steady, voluminous stream of very uniform parts, all positioned and oriented precisely so that the high-speed machines can operate without jamming or stopping. Machines and instrumentation are better than humans in monitoring and responding rapidly and consistently to many stimuli simultaneously—some beyond the range of human capabilities. They also can be made to do several things at once for long periods of time with little variance or deterioration of performance.

Soft, or programmable, automation permits variations in inputs, as it

can sense and adjust for deviations and continue to operate. It is usually faster than manual work but slower than dedicated machines, and its output can permit variations from the standard product so as to achieve marketing and inventory advantages that often more than offset its added cost per unit of output.

In autofacturing, each assembly operation is analyzed to determine whether it is best done manually, with fixed, or with flexible automation. An autofacturing system, then, results in a mixed mode of operation, each with that portion of the product designed to be assembled in the most efficient way available. In it, the actions of conventional machines, automated equipment, human operators, and robots are all interrelated and in balance.

There are over 100 guidelines on how to configure a product and its component piece parts so that they can be assembled as easily and economically as possible. The most important of these rules are as follows:

1. *Minimize and simplify.* Reduce the number of piece parts as much as possible. Determine the essential functions of each part. Transfer functions to other parts. Combine parts. Eliminate as many parts as economically feasible. Simplify before automating.

2. *Modularize.* Design the product such that parts are grouped into modules or sections of the end product. Create modules, like building blocks, so that they can be selected and joined in various ways to make different products. This will aid in assembly, test, repair, and replacement of more manageable subassemblies. It will also make it possible to follow rule 3 below.

3. *Create families of products.* Products should be designed so as to have as much commonality with other products as possible in their modules and piece parts. Products related in a series of escalating capabilities or features can all be built with the same platform (base, power supply, etc.), case, panels, circuit boards, and other common and interchangeable parts. Product distinctions, such as extra features, should be the last components assembled so that the work in process is common for as long as possible. Parts that make a product distinctive should be grouped into the same module. Even seemingly different products can be designed to have the same power supply, switches, gears, and other internal components and modules.

4. *Design parts to have as many different uses as possible,* depending on how they are installed and which portion of them is used. Determine whether the extra cost of the added complexity is more than offset by the benefits.

5. *Use the best overall method to make each part.* That is, consider not only its fabrication costs, but the relative costs of handling, subsequence operations, assembly, inspection, scrap, etc.

6. *Design in layers.* Where possible, design the product so that it is made up of layers of components, such that making it requires the adding of one layer on top of another, built up from the base to the cover or outer case. See Fig. 17.7.2.

7. *Assemble in short, straight vertical strokes.* If rule 6, above, is observed, then this should be possible. Avoid the need for lateral, curved, or complex motion paths in assembling components. Minimize the number of directions of assembly. Minimize the amount of lifting, rotating, and other handling of the components, subassemblies, or product. See Fig. 17.7.2.

8. *Present parts appropriately.* Bring parts to the machines, robots, and human operators in the position and orientation best suited to use without the need for rehandling or repositioning. Hold them in trays, on reels, in connected strips, etc. rather than disoriented in a tote box or bin. Parts stamped from strips or molded should be left on their webs as long as possible, for they are orderly. Parts to be fed to assembly stations by vibratory bowl feeders should be designed so as to feed through easily and not jam, snag, tangle, nest, shingle, bridge, or interlock.

9. *Design for symmetry and orientation.* To the degree possible, design parts to be symmetrical so that no matter what position they are in, it is proper for assembly. If perfect symmetry is not possible, strive to have the parts go together in as many ways as possible. Where that is not possible, accentuate the asymmetry and give the parts an orientation feature, so that a person or robot can easily sense it and orient the part correctly. See Fig. 17.7.2.

10. *Make errors impossible.* Design the product and its parts so that the components physically cannot be assembled wrong. If a part has internal or hard-to-sense features, add a feature that can be sensed, even if it has no operational function. Do not have the dimensions of a part be too similar if the part's proper orientation and assembly depend on discerning a small difference.

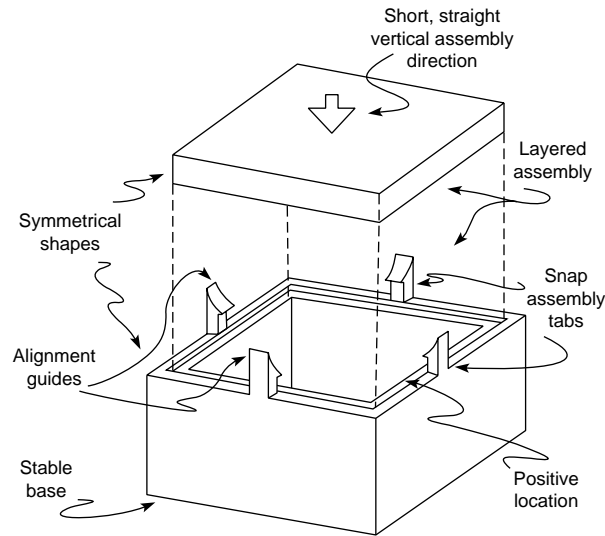

Fig. 17.7.2 Selected design for assembly guidelines.

11. *Give each part a positive location.* Through the use of shoulders, recesses, guides, tabs, and the like, create an exact place where each component is to go. See Fig. 17.7.2.

12. *Minimize fasteners.* Eliminate or reduce to the lowest essential number the product's discrete fasteners. Nuts, bolts, screws, and the like are difficult and expensive to handle and assemble. They should be used only where future disassembly, adjustments, or other needs make them necessary. Very short screws, bolts, and rivets are more difficult to position, as the weight of their heads often makes them fall out of the holes. It is more difficult to place the blade of a driver in screws and bolts with round heads and slotted tops than in those whose tops are flat with closed patterns for the driver's matching blade tips.

13. *Snap in.* Where possible have the parts snap together instead of being held with discrete fasteners. Plastic tabs can be added to a part while it is being molded at negligible extra cost. The operations of placing the part in position for assembly and of assembling it become a single action when it is snapped into place. See Fig. 17.7.2.

14. *Reduce variations.* Where fasteners must be used, have as few variations as possible. Seven or eight different screw sizes can often be reduced to two or three. The added cost of overdesign where a slightly larger size than needed is used is more than made up in purchasing, handling, inventory, record keeping, and tooling savings.

15. *Chamfer.* Assembly can be speeded up and less expensive tooling can be used if holes are chamfered and pins are slightly pointed and rounded. See Fig. 17.7.3.

16. *Avoid problem parts.* Flimsy, amorphous, and long flexible parts such as wire, fabric, insulation, and the like are difficult to handle and should be avoided or provided for in the process. Some coil springs tangle because of their helix and wire diameter or if they are open at their ends.

17. *Help the robot.* Give different parts a common feature so that the same gripper can be used to handle them all. Changing grippers takes time. Extra or complex grippers add to expense. Allow space around components so that the gripper can get in to assemble the part. Design the grippers to fit the contours of the parts or to wrap around them rather than merely hold them with pressure and friction. This will minimize slippage and movement.

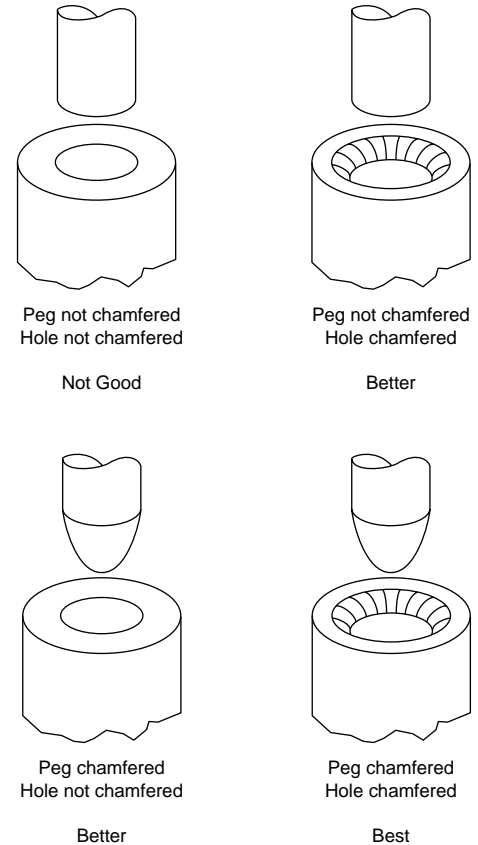

Fig. 17.7.3 The use of chamfers to accommodate slight misalignments.

#### Autofacturing Subsystems

**Material Holding, Feeding, and Metering** In the progression from raw materials and purchased parts to the finished product, the first autofacturing system subsystems are those whose functions are to hold, feed, and meter the correct amount of input to the operating stations. In designating the holding system, the material must be described in detail. Then the required holding status must be defined. Is it to be held in bulk form or as discrete items? Is each item unique or the same as all the others? Must each item be segregated from the others or may they all be commingled at this stage? Then, the best-suited holding devices must be specified, e.g., bins, hoppers, reservoirs, reels, spools, bobbins, trays, racks. Subsequent to holding, the material or parts are to be fed into the next stage of the process. Again, a series of determinations must be made. Are parts to be fed individually or en masse, in metered amounts or at any rate, separated or connected, oriented or unaligned, selectively or randomly, pretested or untested, interruptible or nonstop? Then the most suitable feeding and metering devices must be specified, e.g., dispensers, pumps, applicators, vibratory feeders, escapements. See also Sec. 10.1.

**Operations** The operating stations of the system include those machines, tools, and devices that convert the raw materials to parts or finished products, or bring parts together and assemble them into finished products. It is at these stations that the casting, molding, bending, machining, soldering, welding, riveting, bolting, snapping together, painting, and the like are done. The operators of the machines may be humans or robots or the machines may be designed to operate automatically or under the direction of a computer.

**Transferring** When more than one operation is required, means of transferring the work in process from one machine or station to the next must be provided. In many companies, the time that material is on a

## 17-44 AUTOMATIC MANUFACTURING

machine and being processed is much less than the time it is being unfixtured from the machine, moved to the next machine and fixtured in it, with several delays, storages, and handlings in between. Work can also be transferred while on a machine, but to other tooling or test stations of it. Some such machines are the in-line (or straight line) pallet (or platen) and plain (or nonpallet) transfer machines and the dial (or turret) rotary table machines. These may move continuously or intermittently (indexing). They may be of the trunnion, center column, or shuttle-table type and may be purchased as standard or special custom designs. Robots and other mechanisms are often used to transfer work from station to station within a machine and between machines. See Secs. 10.5 and 10.6. It is important that the inputs and outputs of the individual stations and machines be in balance, in order to avoid idle equipment and work-in-process buildups.

**Sensing** There will be many points within an autofacturing system at which the sensing of conditions will be required. Sensing is a function which usually must be done prior to measurement, inspection/test, counting, sorting, computing, actuating/moving, feedback/control, and correction. Sensors can be used to measure position, presence or proximity, characteristics, or conditions of the parts, product, machines, tooling/fixture, equipment, people, and environment. Contact-type sensors include mechanical, electromechanical, electrical, chemical, and air jet. Noncontact-type sensors include permanent magnet, electro-magnet, capacitance, inductance, reluctance (magnet and variable), sonic/ultrasonic, photoelectric/optoelectronic, laser, radio frequency, eddy current, thermal and relative expansion, Hall effect, air (pressure and fluidic), and inertial/accelerometer.

In deciding whether to use a sensor, where, and what type, the questions to ask are

1. What *should* happen?
2. What *could* happen?
3. What measurable phenomena, conditions, data, features, properties, changes, etc. will be present to distinguish item 2 from item 1?
4. When is the earliest that item 3 can be detected?
5. Where? How?
6. What is the best sensor or combination of sensors to do this?
7. What should be done with the information sensed?

**Measurement, Inspection, and Test** In autofacturing, it is essential that the product be inspected while on the machines and while it is being made. The objective is to make only good products. To do this, critical parameters are sensed and measured in real time. If they begin to drift beyond preset statistical limits, error signals are fed back and adjustments in the machine are made automatically to bring the variables back in control before any bad products are made. It is important, therefore, that the product be designed so that there is access to inspection and test points during processing. It also means that the machines should include sensors and inspection stations amid the processing stations.

**Equipment Monitoring and Performance Maintenance** In addition to the product, all of the machines and equipment must be monitored constantly to assure continued peak performance and to avoid breakdowns. Again, a multitude of sensors, clocks, and counters is a must for the measurement, feedback, correction, and control of the status of the system. For tooling, where wear is certain, automatic tool changers that pull the used tool out and replace it with a new one can be used. An operator or maintenance person then removes the used tool from the device and loads it with another new one so the tool changer is ready again. In some cases, duplicate modular workstations are kept on hand so that a malfunctioning one can be replaced rapidly.

**Sorting, Counting, and Marking** After the product is made, its characteristics can be sensed and measured and it can be sorted according to whatever decision rules are set. Deflection devices—such as conveyor belt gates, air jets, and the like—can be used to divert each class of product to its own receptacle. They can then be counted (with the data going to the computer) and marked or labeled, as desired.

**Wrapping and Packaging** The wrapping and packaging of the

product is just as much an integrated part of the overall system as is assembly, and should be just as automated. Even the packing cartons should be designed to facilitate automated operations. Instead of conventional flaps that tend to close and block the robot's path in trying to put products in, boxes should have straight sides and a lid so that both the products and the lid can be handled in straight, vertical motions.

**Automated Material Handling and Automated Warehousing** An aim of autofacturing is to have the raw material and purchased parts flow from the receiving department to the shipping department as smoothly and with as few stops, temporary storages, and handlings as possible as they are gradually converted to finished products. To do this, automated material handling and warehousing equipment must be installed whose capacities are in balance with the outputs of the production machines. The equipment available ranges from forklift trucks and automatic guided vehicles (AGV) to robots and automatic storage and retrieval systems (AS/RS). See Sec. 10.7 and the other sections cited above for descriptions of such equipment.

**Order Picking, Packing, and Shipping** The automation of the factory does not end with the production and storage of the products. As orders are received, the correct number of the correct items must be picked, packed, and shipped from inventory. A perfect autofacturing system would be one wherein the production and demand for items is so balanced that products are shipped directly from the final production and inspection station. In all cases, the receipt of orders should be entered into the same computer system that schedules production so that the match between what is being sold and what is being made is as close as possible.

**Operator/Machine Interfaces** Even the most automatic machines occasionally require the attention of a human attendant or maintenance person. The fields of study that examine the human/machine interfaces and the degrees of effort and responses of people at work are called *human engineering, human factors engineering, biomechanics, ergonomics, and cybernetics*. While each concentrates on a particular aspect of the subject, they are all concerned with matching the needs and capabilities of humans to the designs of the machines (and total environment) with which they interface. Humans control machines via buttons, knobs, handles, switches, keyboards, voice recognition devices, and the like, and these must all be designed, colored, located, etc. to minimize human effort and maximize effectiveness. Machines output information to humans via lights, sounds, dials, gages, video screens, and the like. These, too, must be designed to maximize response and minimize errors. At all times, the human/machine interface must be designed with safety in mind. See Sec. 17.6.

**Communication, Computation, and Control** The system's robots and other equipment have a multitude of microprocessors embedded in them. That, and the fact that they also have many sophisticated sensors justifies calling them "smart" machines. They, in turn, are controlled by more powerful microcomputers that report to minicomputers, thence to a powerful central host computer. The host computer does not control each detail of the system; it merely integrates and balances a distributed and hierarchical communication, computation, and control capability that uses the same database and is linked by a local-area network (LAN).

**Auxiliary Systems** There are several ancillary systems that can be employed to enhance automated manufacturing and the autofacturing system. Some of these are group technology (GT), concurrent engineering or simultaneous engineering, and computer-aided design and computer-aided manufacturing (CAD/CAM) in the product design and prototyping stages; just-in-time (JIT) delivery, material requirements planning (MRP), and manufacturing resources planning (MRP II) in the production planning and inventory control stages; computer-aided testing (CAT) and total quality control (TQC) in the production, inspection, and testing stages; computer-integrated manufacturing (CIM) in the communication, computation, and control stages; and management information systems (MISs) in the reporting and analysis stages.